

DENISON HYDRAULICS T6C - T6CM

vane-type single pump / flügelzellen-Einzelpumpe
pompe simple à palettes / pompa semplice a palette
tipo bomba de paletas simple
service information

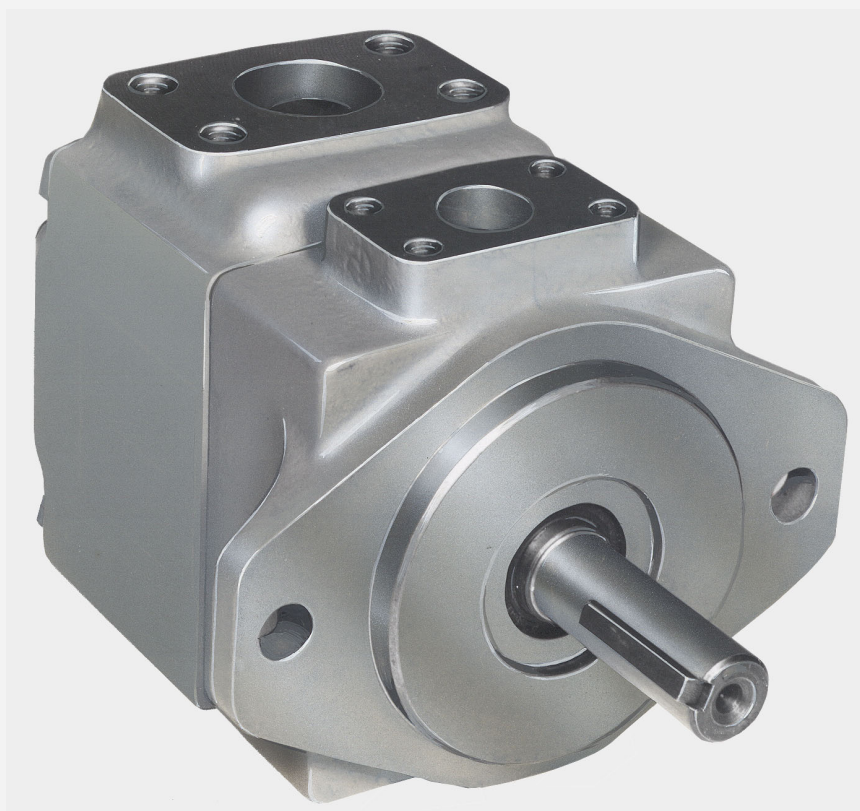

Publ. S1 - ML0501 - B

02 / 2003 / FB

Replaces : S1 - ML0501 - A

L25 - 10501 - 2

DENISON | **Hydraulics**

Recommended repair kits and assy's are bold printed
 Empfohlene Austausch - Baugruppen sind fett gedruckt
 Les pochettes de rechange recommandées sont imprimées en caractères gras
 I kit di ricambio consigliati sono indicati in grassetto
 Los juegos de reparacion recomendados y los conjuntos, estan en negrita

Item - Pos. - Réf. - Pos.	
	22
Mounting torque	
Anziehdrehmoment	159 Nm
Couple de serrage	117 ft.lbs
Coppia di serraggio	
Par de apriete	

T6C INDUSTRIAL

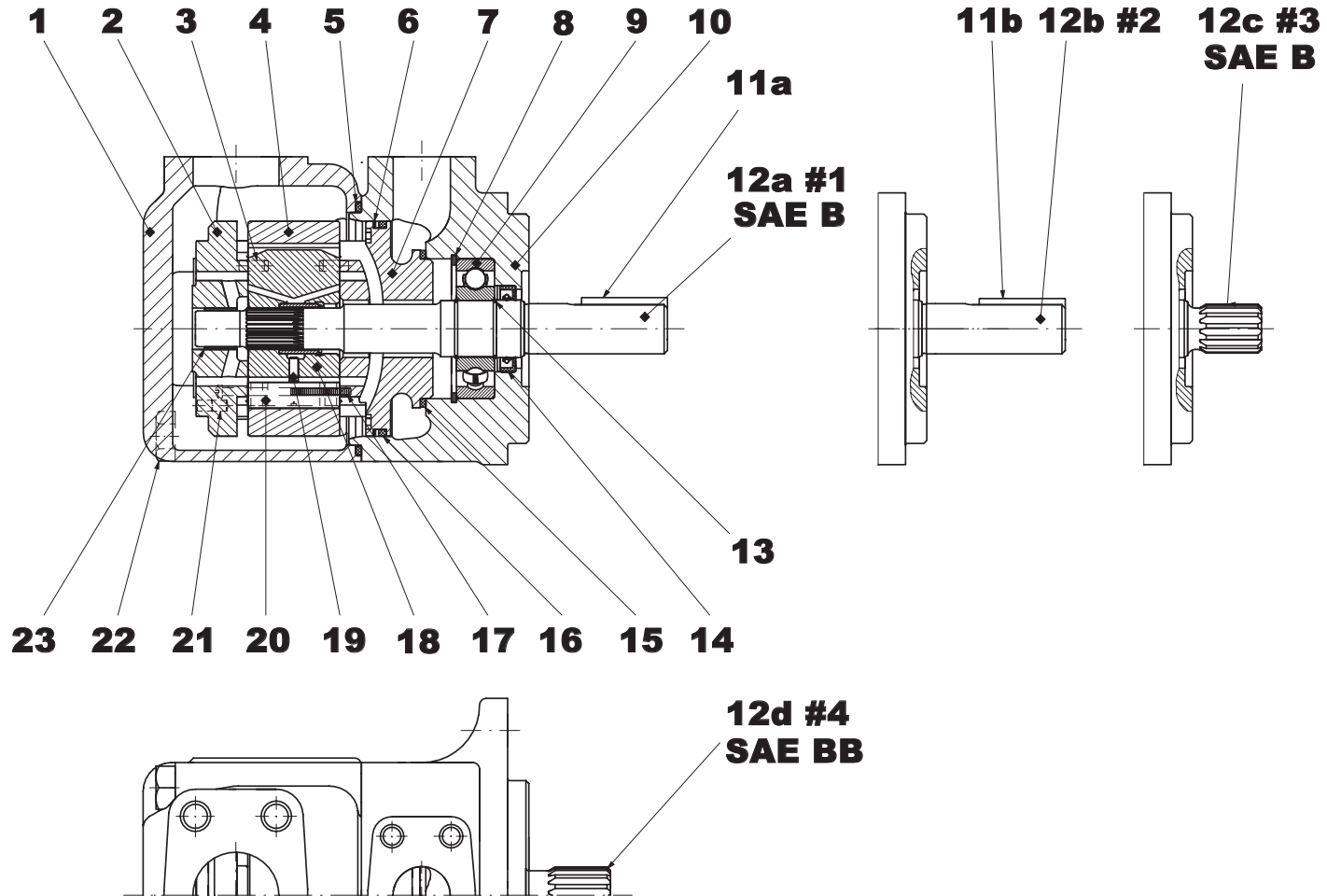

Recommended repair kits and assy's are bold printed
 Empfohlene Austausch - Baugruppen sind fett gedruckt
 Les pochettes de rechange recommandées sont imprimées en caractères gras
 I kit di ricambio consigliati sono indicati in grassetto
 Los juegos de reparacion recomendados y los conjuntos, estan en negrita

Item - Pos. - Réf. - Pos.	
	22
Mounting torque	
Anziehdrehmoment	159 Nm
Couple de serrage	117 ft.lbs
Coppia di serraggio	
Par de apriete	

T6CM MOBILE

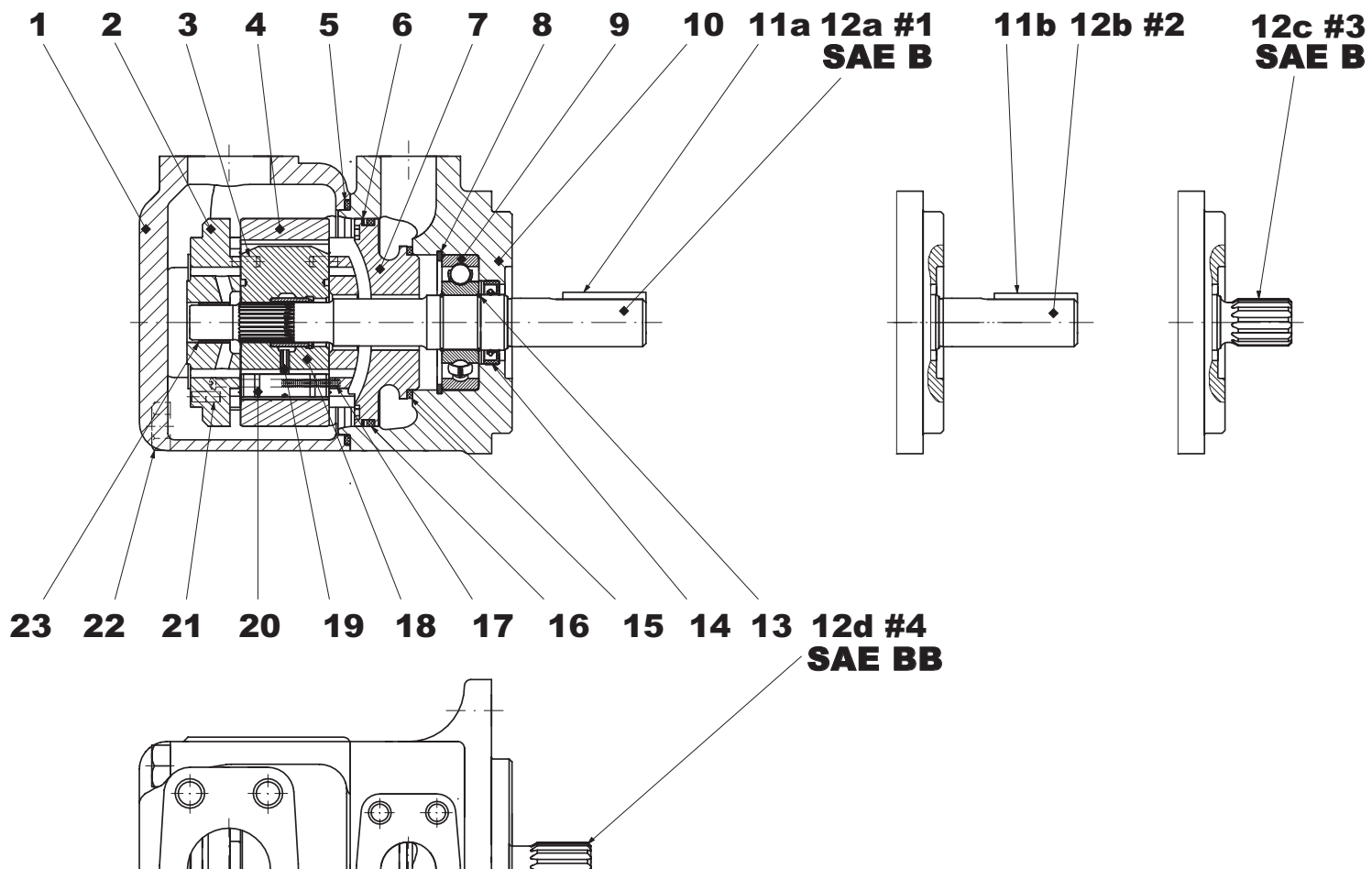

Item Pos. Ref. Pos.	Description Descrizione	Benennung Descripción	Description		Part N° Teil Nr. Code N° Referencia T6C	Part N° Teil Nr. Code N° Referencia T6CM	Qty Stück Qté Cant.
1	Housing (standard) <i>Corpo (standard)</i>	Gehäuse (Standard) <i>Cuerpo (estandar)</i>	Carter (standard)		034.48564		1
2	Port plate-rear C.C.W. <i>Piatto distributore post. antioraria</i>	Steuerplatte Linkslauf <i>Plato distribuidor trasero giro I</i>	Plaque arrière rotation gauche	AG	034.59775		1
	Port plate-rear C.W. <i>Piatto distributore post. oraria</i>	Steuerplatte Rechtslauf <i>Plato distribuidor trasero giro D</i>	Plaque arrière rotation droite	AG	034.59774		1
	Port plate-rear <i>Piatto distributore</i>	Steuerplatte <i>Plato distribuidor trasero</i>	Plaque arrière	AG		034.59047	1
3	Dowel pin <i>Spina</i>	Zentrierstift <i>Pasador</i>	Goupille	A	324.21208		2
4	Cam ring 003 <i>Anello camma 003</i>	Hubring 003 <i>Aro volumetrico 003</i>	Came 003	A	034.59050		1
	Cam ring 005 <i>Anello camma 005</i>	Hubring 005 <i>Aro volumetrico 005</i>	Came 005	A	034.59051		1
	Cam ring 006 <i>Anello camma 006</i>	Hubring 006 <i>Aro volumetrico 006</i>	Came 006	A	034.59052		1
	Cam ring 008 <i>Anello camma 008</i>	Hubring 008 <i>Aro volumetrico 008</i>	Came 008	A	034.59053		1
	Cam ring 010 <i>Anello camma 010</i>	Hubring 010 <i>Aro volumetrico 010</i>	Came 010	A	034.59054		1
	Cam ring 012 <i>Anello camma 012</i>	Hubring 012 <i>Aro volumetrico 012</i>	Came 012	A	034.66595		1
	Cam ring 014 <i>Anello camma 014</i>	Hubring 014 <i>Aro volumetrico 014</i>	Came 014	A	034.59206		1
	Cam ring 017 <i>Anello camma 017</i>	Hubring 017 <i>Aro volumetrico 017</i>	Came 017	A	034.59207		1
	Cam ring 020 <i>Anello camma 020</i>	Hubring 020 <i>Aro volumetrico 020</i>	Came 020	A	034.66607		1
	Cam ring 022 <i>Anello camma 022</i>	Hubring 022 <i>Aro volumetrico 022</i>	Came 022	A	034.59208		1
	Cam ring 025 <i>Anello camma 025</i>	Hubring 025 <i>Aro volumetrico 025</i>	Came 025	A	034.59209		1
	Cam ring 028 <i>Anello camma 028</i>	Hubring 028 <i>Aro volumetrico 028</i>	Came 028	A	034.59245		1
	Cam ring 031 <i>Anello camma 031</i>	Hubring 031 <i>Aro volumetrico 031</i>	Came 031	A	034.66843		1
5	O.ring <i>Guarnizione</i>	Dichtring <i>Guarnizione torica</i>	Joint torique	AB	671.00244		1
6	Back-up ring <i>Anello anti-estrusione</i>	Stützring <i>Anillo</i>	Bague anti-extrusion	AB	618.00010.3		1
7	Port plate-pressure C.C.W. <i>Piatto distributore anter. antioraria</i>	Steuerplatte Linkslauf <i>Plato distribuidor-presión giro I</i>	Plaque pression rotation gauche	A	034.59773		
	Port plate-pressure C.W. <i>Piatto distributore anter. oraria</i>	Steuerplatte Rechtslauf <i>Plato distribuidor-presión giro D</i>	Plaque pression rotation droite	A	034.59772		

Item Pos. Ref. Pos.	Description Descrizione	Benennung Descripción	Description		Part N° Teil Nr. Code N° Referencia T6C	Part N° Teil Nr. Code N° Referencia T6CM	Qty Stück Qté Cant.
7	Port plate-pressure <i>Piatto distributore anter.</i>	Steuerplatte <i>Plato distribuidor-presión</i>	Plaque pression	A		034.66453	1
8	Retaining ring <i>Anello elastico</i>	Sicherungsring <i>Anillo de retención</i>	Circlips		356.30244		1
9	Ball bearing <i>Cuscinetto a sfera</i>	Kugellager <i>Cojinete de bolas</i>	Roulement à billes		230.82054		1
10	Mounting cap (standard) <i>Coperchio (standard)</i>	Deckel (Standard) <i>Tapa de montage (estandar)</i>	Chapeau de montage (standard)		034.48565		1
11a	Key (code 1) <i>Chiavetta (codice 1)</i>	Paßfeder (Typ 1) <i>Chaveta (codigo 1)</i>	Clavette (code 1)	C	034.48690		1
11b	Key (code 2) <i>Chiavetta (codice 2)</i>	Paßfeder (Typ 2) <i>Chaveta (codigo 2)</i>	Clavette (code 2)	D	034.49622		1
12a	Shaft (keyed) (code 1) (SAE B) <i>Albero a chiavetta (codice 1) (SAE B)</i>	Paßfederwelle (Typ 1) (SAE B) <i>Eje chaveteado (codigo 1) (SAE B)</i>	Arbre à clavette (code 1) (SAE B)	C	034.70814		1
12b	Shaft (keyed) (code 2) <i>Albero a chiavetta (codice 2)</i>	Paßfederwelle (Typ 2) <i>Eje chaveteado (codigo 2)</i>	Arbre à clavette (code 2)	D	034.70880		1
12c	Shaft (splined) (code 3) (SAE B) <i>Albero scanalato (codice 3) (SAE B)</i>	Vielkeilwelle (Typ 3) (SAE B) <i>Eje estriado (codigo 3) (SAE B)</i>	Arbre à cannelures (code 3) (SAE B)	E	034.70815		1
12d	Shaft (splined) (code 4) (SAE BB) <i>Albero scanalato (codice 4) (SAE BB)</i>	Vielkeilwelle (Typ 4) (SAE BB) <i>Eje estriado (codigo 4) (SAE BB)</i>	Arbre à cannelures (code 4) (SAE BB)	F		034.59426	1
13	Round section ring <i>Anello</i>	Sicherungsring <i>Anillo tórico</i>	Anneau		034.70777		2
14	Shaft seal (S1 - 0,7 bar) <i>Paraolio (S1 - 0,7 bar)</i>	Simmerring (S1 - 0,7 bar) <i>Reten eje (S1 - 0,7 bar)</i>	Joint d'arbre (S1 - 0,7 bar)	B	620.82012		1
	Shaft seal (S4 - S5 - 7 bar) <i>Paraolio (S1 - 7 bar)</i>	Simmerring (S4 - S5 - 7 bar) <i>Reten eje (S4 - S5 - 7 bar)</i>	Joint d'arbre (S4 - S5 - 7 bar)	B	620.82068		1
15	Sq. section seal <i>Guarnizione</i>	Dichtring <i>Junta seccion cuadrada</i>	Joint section carrée	AB	691.10229		1
16	Sq. section seal <i>Guarnizione</i>	Dichtring <i>Junta seccion cuadrada</i>	Joint section carrée	AB	691.10238		1
17	Screw <i>Vite</i>	Schraube <i>Tornille</i>	Vis	A	317.06266		2
18	Rotor-insert ass'y <i>Insieme rotore</i>	Rotor <i>Conjunto rotor</i>	Rotor et douille ass.	A	S24.10116	S24.30049	1
19	Pin-vane holdout <i>Pistoncino di sostentamento</i>	Stössel <i>Espiga empuje paleta</i>	Poussoir de palette	A	034.59098	034.24982	10
20	Vane <i>Paletta</i>	Flügel <i>Paleta</i>	Palette	A	034.59099	034.66716	10
21	Dowel pin <i>Spina</i>	Zentrierstift <i>Pasador</i>	Goupille	AG	323.82010		1
22	Screw <i>Vite</i>	Schraube <i>Tornille</i>	Vis		306.40038		4
23	Bush <i>Bussola</i>	Buchse <i>Cojinete de fricción</i>	Bague	AG	034.71867		1

Item Pos. Ref. Pos.	Description Descrizione	Benennung Descripcion	Description	Part N° Teil Nr. Code N° Referencia T6C	Part N° Teil Nr. Code N° Referencia T6CM	Qty Stück Qté Cant.
	REPAIR KIT KIT DI RICAMBIO	AUSTAUSCH-BAUGRUPPEN CONJUNTO REPARACION	POCHETTES RECHANGES			
A	Cart. and plate ass'y *03 C.W. Ins. cart. *03 oraria	Pumpeneinheit *03 Rechtslauf Conjunto cart. y platos *03 giro d.	Cart. et plaque ass. *03 rot. d.	S24.10692	S24.30097	1
A	Cart. and plate ass'y *03 C.C.W. Ins. cart. *03 antioraria	Pumpeneinheit *03 Linkslauf Conjunto cart. y platos *03 giro i.	Cart. et plaque ass. *03 rot. g.	S24.10693	S24.30098	1
A	Cart. and plate ass'y *05 C.W. Ins. cart. *05 oraria	Pumpeneinheit *05 Rechtslauf Conjunto cart. y platos *05 giro d.	Cart. et plaque ass. *05 rot. d.	S24.10694	S24.30099	1
A	Cart. and plate ass'y *05 C.C.W. Ins. cart. *05 antioraria	Pumpeneinheit *05 Linkslauf Conjunto cart. y platos *05 giro i.	Cart. et plaque ass. *05 rot. g.	S24.10695	S24.30100	1
A	Cart. and plate ass'y *06 C.W. Ins. cart. *06 oraria	Pumpeneinheit *06 Rechtslauf Conjunto cart. y platos *06 giro d.	Cart. et plaque ass. *06 rot. d.	S24.10696	S24.30101	1
A	Cart. and plate ass'y *06 C.C.W. Ins. cart. *06 antioraria	Pumpeneinheit *06 Linkslauf Conjunto cart. y platos *06 giro i.	Cart. et plaque ass. *06 rot. g.	S24.10697	S24.30102	1
A	Cart. and plate ass'y *08 C.W. Ins. cart. *08 oraria	Pumpeneinheit *08 Rechtslauf Conjunto cart. y platos *08 giro d.	Cart. et plaque ass. *08 rot. d.	S24.10698	S24.30103	1
A	Cart. and plate ass'y *08 C.C.W. Ins. cart. *08 antioraria	Pumpeneinheit *08 Linkslauf Conjunto cart. y platos *08 giro i.	Cart. et plaque ass. *08 rot. g.	S24.10699	S24.30104	1
A	Cart. and plate ass'y *10 C.W. Ins. cart. *10 oraria	Pumpeneinheit *10 Rechtslauf Conjunto cart. y platos *10 giro d.	Cart. et plaque ass. *10 rot. d.	S24.10721	S24.30105	1
A	Cart. and plate ass'y *10 C.C.W. Ins. cart. *10 antioraria	Pumpeneinheit *10 Linkslauf Conjunto cart. y platos *10 giro i.	Cart. et plaque ass. *10 rot. g.	S24.10722	S24.30106	1
A	Cart. and plate ass'y *12 C.W. Ins. cart. *12 oraria	Pumpeneinheit *12 Rechtslauf Conjunto cart. y platos *12 giro d.	Cart. et plaque ass. *12 rot. d.	S24.26478	S24.30107	1
A	Cart. and plate ass'y *12 C.C.W. Ins. cart. *12 antioraria	Pumpeneinheit *12 Linkslauf Conjunto cart. y platos *12 giro i.	Cart. et plaque ass. *12 rot. g.	S24.26479	S24.30108	1
A	Cart. and plate ass'y *14 C.W. Ins. cart. *14 oraria	Pumpeneinheit *14 Rechtslauf Conjunto cart. y platos *14 giro d.	Cart. et plaque ass. *14 rot. d.	S24.10723	S24.30109	1
A	Cart. and plate ass'y *14 C.C.W. Ins. cart. *14 antioraria	Pumpeneinheit *14 Linkslauf Conjunto cart. y platos *14 giro i.	Cart. et plaque ass. *14 rot. g.	S24.10724	S24.30110	1
A	Cart. and plate ass'y *17 C.W. Ins. cart. *17 oraria	Pumpeneinheit *17 Rechtslauf Conjunto cart. y platos *17 giro d.	Cart. et plaque ass. *17 rot. d.	S24.10725	S24.30111	1
A	Cart. and plate ass'y *17 C.C.W. Ins. cart. *17 antioraria	Pumpeneinheit *17 Linkslauf Conjunto cart. y platos *17 giro i.	Cart. et plaque ass. *17 rot. g.	S24.10726	S24.30112	1
A	Cart. and plate ass'y *20 C.W. Ins. cart. *20 oraria	Pumpeneinheit *20 Rechtslauf Conjunto cart. y platos *20 giro d.	Cart. et plaque ass. *20 rot. d.	S24.26859	S24.30113	1
A	Cart. and plate ass'y *20 C.C.W. Ins. cart. *20 antioraria	Pumpeneinheit *20 Linkslauf Conjunto cart. y platos *20 giro i.	Cart. et plaque ass. *20 rot. g.	S24.26860	S24.30114	1
A	Cart. and plate ass'y *22 C.W. Ins. cart. *22 oraria	Pumpeneinheit *22 Rechtslauf Conjunto cart. y platos *22 giro d.	Cart. et plaque ass. *22 rot. d.	S24.10727	S24.30115	1
A	Cart. and plate ass'y *22 C.C.W. Ins. cart. *22 antioraria	Pumpeneinheit *22 Linkslauf Conjunto cart. y platos *22 giro i.	Cart. et plaque ass. *22 rot. g.	S24.10728	S24.30116	1
A	Cart. and plate ass'y *25 C.W. Ins. cart. *25 oraria	Pumpeneinheit *25 Rechtslauf Conjunto cart. y platos *25 giro d.	Cart. et plaque ass. *25 rot. d.	S24.10729	S24.30117	1

Item Pos. Ref. Pos.	Description Descrizione	Benennung Descripción	Description	Part N° Teil Nr. Code N° Referencia T6C	Part N° Teil Nr. Code N° Referencia T6CM	Qty Stück Qté Cant.
A	Cart. and plate ass'y *25 C.C.W. <i>Ins. cart. *25 antioraria</i>	Pumpeneinheit *25 Linkslauf <i>Conjunto cart. y platos *25 giro i.</i>	Cart. et plaque ass. *25 rot. g.	S24.10730	S24.30118	1
A	Cart. and plate ass'y *28 C.W. <i>Ins. cart. *28 oraria</i>	Pumpeneinheit *28 Rechtslauf <i>Conjunto cart. y platos *28 giro d.</i>	Cart. et plaque ass. *28 rot. d.	S14.97761	S24.30119	1
A	Cart. and plate ass'y *28 C.C.W. <i>Ins. cart. *28 antioraria</i>	Pumpeneinheit *28 Linkslauf <i>Conjunto cart. y platos *28 giro i.</i>	Cart. et plaque ass. *28 rot. g.	S24.25519	S24.30120	1
A	Cart. and plate ass'y *31 C.W. <i>Ins. cart. *31 oraria</i>	Pumpeneinheit *31 Rechtslauf <i>Conjunto cart. y platos *31 giro d.</i>	Cart. et plaque ass. *31 rot. d.	S24.45785	S24.45791	1
A	Cart. and plate ass'y *31 C.C.W. <i>Ins. cart. *31 antioraria</i>	Pumpeneinheit *31 Linkslauf <i>Conjunto cart. y platos *31 giro i.</i>	Cart. et plaque ass. *31 rot. g.	S24.45786	S24.45792	1
B	Seal kit (S1 - 0,7 bar) <i>Serie guarnizioni (S1 - 0,7 bar)</i>	Dichtringsatz (S1 - 0,7 bar) <i>Juego de juntas (S1 - 0,7 bar)</i>	Pochette de joint (S1 - 0,7 bar)	S24.10133		1
	Seal kit (S4 - 7 bar) <i>Serie guarnizioni (S4 - 7 bar)</i>	Dichtringsatz (S4 - 7 bar) <i>Juego de juntas (S4 - 7 bar)</i>	Pochette de joint (S4 - 7 bar)	S24.10133.4		1
	Seal kit (S5 - 7 bar) <i>Serie guarnizioni (S5 - 7 bar)</i>	Dichtringsatz (S5 - 7 bar) <i>Juego de juntas (S5 - 7 bar)</i>	Pochette de joint (S5 - 7 bar)	S24.10133.5		1
C	Shaft and bearing ass'y (code 1) <i>Ins. albero (codice 1)</i>	Baugruppe (Welle u. Lager) (Typ 1) <i>Conjunto eje cojinete (codigo 1)</i>	Arbre et roulement ass. (code 1)	S14.24570		1
D	Shaft and bearing ass'y (code 2) <i>Ins. albero (codice 2)</i>	Baugruppe (Welle u. Lager) (Typ 2) <i>Conjunto eje cojinete (codigo 2)</i>	Arbre et roulement ass. (code 2)	S14.25645		1
E	Shaft and bearing ass'y (code 3) <i>Ins. albero (codice 3)</i>	Baugruppe (Welle u. Lager) (Typ 3) <i>Conjunto eje cojinete (codigo 3)</i>	Arbre et roulement ass. (code 3)	S14.24569		1
F	Shaft and bearing ass'y (code 4) <i>Ins. albero (codice 4)</i>	Baugruppe (Welle u. Lager) (Typ 4) <i>Conjunto eje cojinete (codigo 4)</i>	Arbre et roulement ass. (code 4)		S24.10430	1
G	Port plate-rear and bush ass'y C.C.W. <i>Ins. piatto distributore post. antioraria</i>	Steuerplatte mit Buchse Linkslauf <i>Conj. plato dist. tras. con coj. fricción giro I</i>	Plaque ar. et bague ass. rot. gauche	S24.10804		1
	Port plate-rear and bush ass'y C.W. <i>Ins. piatto distributore post. oraria</i>	Steuerplatte mit Buchse Rechtslauf <i>Conj. plato dist. tras. con coj. fricción giro D</i>	Plaque ar. et bague ass. rot. droite	S24.10803		1
	Port plate-rear and bush ass'y <i>Ins. piatto distributore post.</i>	Steuerplatte mit Buchse <i>Conj. plato dist. tras. con coj. fricción</i>	Plaque ar. et bague ass.		S14.45605	1
Notes						

Model Code

Typenschlüssel

Designation - type

Model number :

Typenbezeichnung :

Numéro du modèle :

T6C . - 022 - 1 R 00 - B 1 - ..

Series _____

Baureihe _____

Série _____

One letter can be added to specify special parts in series _____

Optionen _____

Une lettre peut être ajoutée pour spécifier les pièces spéciales dans la série. _____

Cam ring _____

Hubring _____

Came _____

(Volumetric displacement) (ml/rev.)

(Geometrisches Fördervolumen) (cm³/U)

(Cylindree théorique) (cm³/tr)

003 = 10,8

012 = 37,1

022 = 70,3

005 = 17,2

014 = 46,0

025 = 79,3

006 = 21,3

017 = 58,3

028 = 88,8

008 = 26,4

020 = 63,8

031 = 100,0

010 = 34,1

Type of shaft _____

Art der Welle _____

Type d'arbre _____

1 = keyed (SAE B)

1 = Paßfederwelle (SAE B)

1 = à clavette (SAE B)

2 = keyed (no SAE)

2 = Paßfederwelle (no SAE)

2 = à clavette (no SAE)

3 = splined (SAE B)

3 = Vielkeilwelle (SAE B)

3 = à cannelures (SAE B)

4 = splined (SAE BB)

4 = Vielkeilwelle (SAE BB)

4 = à cannelures (SAE BB)

Direction of rotation _____

Drehrichtung _____

Sens de rotation _____

R = Clockwise

R = Rechtslauf

R = à droite

L = Counter-clockwise

L = Linkslauf

L = à gauche

Porting combination _____

Lage der Anschlüsse _____

Combinaison des orifices _____

00 = standard

00 = standard

00 = standard

Design letter _____

Ausführungsbuchstabe _____

Conception _____

Seal class _____

Dichtungsklasse _____

Classe de joint _____

1 = S1 - BUNA N

1 = S1 - BUNA N

1 = S1 - BUNA N

4 = S4 - EPDM

4 = S4 - EPDM

4 = S4 - EPDM

5 = S5 - VITON

5 = S5 - VITON

5 = S5 - VITON

Modifications _____

Modifikationen _____

Modifications _____

Designazione

Clave de designación

Sigla : _____

Referencia modelo : _____

T6C . - 022 - 1 R 00 - B 1 - ..

Serie _____

Serie _____

Una lettera può essere aggiunta per specificare parti speciali nella serie

Una letra puede ser añadida para especificar piezas especiales en la serie

Tipo di cartuccia _____

(Cilindrata) (ml/giro)

003 = 10,8
005 = 17,2
006 = 21,3
008 = 26,4
010 = 34,1
012 = 37,1
014 = 46,0

Aro volumetrico _____

(Cilindrata) (ml/rev)

017 = 58,3
020 = 63,8
022 = 70,3
025 = 79,3
028 = 88,8
031 = 100,0

Tipo di albero _____

1 = a chiavetta (SAE B)
2 = a chiavetta (no SAE)
3 = scanalato (SAE B)
4 = scanalato (SAE BB)

Tipo de eje _____

1 = chaveteado (SAE B)
2 = chaveteado (no SAE)
3 = estriado (SAE B)
4 = estriado (SAE BB)

Senso di rotazione _____

R =orario
L = Antiorario

Sentido de giro _____

R = Derecha
L = Izquierda

Orientamento delle bocche _____

00 = standard

Posición de bocas _____

00 = estándar

Disegno _____

Letra de diseño _____

Tipo di guarnizioni _____

1 = S1 - BUNA N
4 = S4 - EPDM
5 = S5 - VITON

Clase de juntas _____

1 = S1 - BUNA N
4 = S4 - EPDM
5 = S5 - VITON

Modifiche _____

Modificaciones _____

Model Code

Model number :

Series M = Mobile 1 shaft seal _____

One letter can be added to specify special parts in series _____

Cam ring

(Volumetric displacement) (ml/rev.)

B03 = 10,8
B05 = 17,2
B06 = 21,3
B08 = 26,4
B10 = 34,1

Type of shaft

1 = keyed (SAE B)
2 = keyed (no SAE)
3 = splined (SAE B)
4 = splined (SAE BB)

Direction of rotation

R = Clockwise
L = Counter-clockwise

Porting combination

00 = standard

Design letter

Seal class

1 = S1 - BUNA N
4 = S4 - EPDM
5 = S5 - VITON

Modifications

Typenschlüssel

Typenbezeichnung :

Serie M = Mobil, 1 Wellendichtung _____

Optionen _____

Hubring

(Geometrisches Fördervolumen) (cm³/U)

B12 = 37,1
B14 = 46,0
B17 = 58,3
B20 = 63,8

Art der Welle

1 = Paßfederwelle (SAE B)
2 = Paßfederwelle (no SAE)
3 = Vielkeilwelle (SAE B)
4 = Vielkeilwelle (SAE BB)

Drehrichtung

R = Rechtslauf
L = Linkslauf

Lage der Anschlüsse

00 = standard

Ausführungsbuchstabe

Dichtungsklasse

1 = S1 - BUNA N
4 = S4 - EPDM
5 = S5 - VITON

Modifikationen

Designation - type

Numéro du modèle :

Série M = Mobile 1 joint d'arbre _____

Une lettre peut être ajoutée pour spécifier les pièces spéciales dans la série. _____

Came

(Cylindrée théorique) (cm³/tr)

B22 = 70,3
B25 = 79,3
B28 = 88,8
B31 = 100,0

Type d'arbre

1 = à clavette (SAE B)
2 = à clavette (no SAE)
3 = à cannelures (SAE B)
4 = à cannelures (SAE BB)

Sens de rotation

R = à droite
L = à gauche

Combinaison des orifices

00 = standard

Conception

Classe de joint

1 = S1 - BUNA N
4 = S4 - EPDM
5 = S5 - VITON

Modifications

T6CM . - B22 - 1 R 00 - C 1 - ..

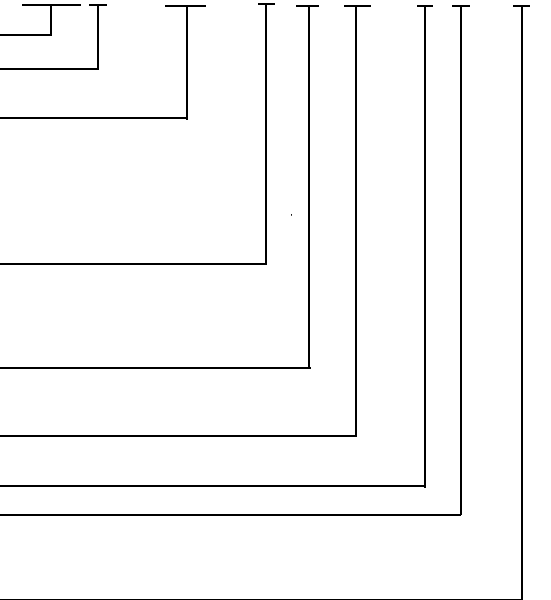

Designazione

Clave de designación

Sigla :

Referencia modelo :

T6CM . - B22 - 1 R 00 - C 1 - ..

Serie M = Mobile 1 guarnizione albero _____

Serie M = Movil 1 reten eje _____

Una lettera può essere aggiunta per specificare parti speciali nella serie _____

Una letra puede ser añadida para especificar piezas especiales en la serie _____

Tipo di cartuccia

(Cilindrata) (ml/giro)

B03 = 10,8

B05 = 17,2

B06 = 21,3

B08 = 26,4

B10 = 34,1

B12 = 37,1

B14 = 46,0

Aro volumetrico

(Cilindrata) (ml/rev)

B17 = 58,3

B20 = 63,8

B22 = 70,3

B25 = 79,3

B28 = 88,8

B31 = 100,0

Tipo di albero

1 = a chiave (SAE B)

2 = a chiave (no SAE)

3 = scanalato (SAE B)

4 = scanalato (SAE BB)

Tipo de eje

1 = chaveteado (SAE B)

2 = chaveteado (no SAE)

3 = estriado (SAE B)

4 = estriado (SAE BB)

Senso di rotazione

R = Orario

L = Antiorario

Sentido de giro

R = Derecha

L = Izquierda

Orientamento delle bocche

00 = standard

Posición de bocas

00 = estándar

Disegno

Letra de diseño

Tipo di guarnizioni

1 = S1 - BUNA N

4 = S4 - EPDM

5 = S5 - VITON

Clase de juntas

1 = S1 - BUNA N

4 = S4 - EPDM

5 = S5 - VITON

Modifiche

Modificaciones