

DENISON HYDRAULICS

T67DBB

vane-type triple pump / Flügelzellen-Dreifachpumpe

pompe triple à palettes / pompa tripla a palette

tipo bomba de paletas triple

service information



Publ. S1 - ML0548 - D 08 / 2003 / FB

Replaces : S1 - ML0548 - C

L25 - 10548 - 4

DENISON Hydraulics

Recommended repair kits and assy's are bold printed
 Empfohlene Austausch - Baugruppen sind fett gedruckt
 Les pochettes de rechange recommandées sont imprimées en caractères gras
 I kit di ricambio consigliati sono indicati in grassetto
 Los juegos de reparacion recomendados y los conjuntos, estan en negrita

	Item - Pos. - Réf. - Pos.	
	42	43 - 46
Mounting torque		
Anziehdrehmoment	68 Nm	187 Nm
Couple de serrage	50 ft.lbs	138 ft.lbs
Coppia di serragio		
Par de apriete		

T67DBB

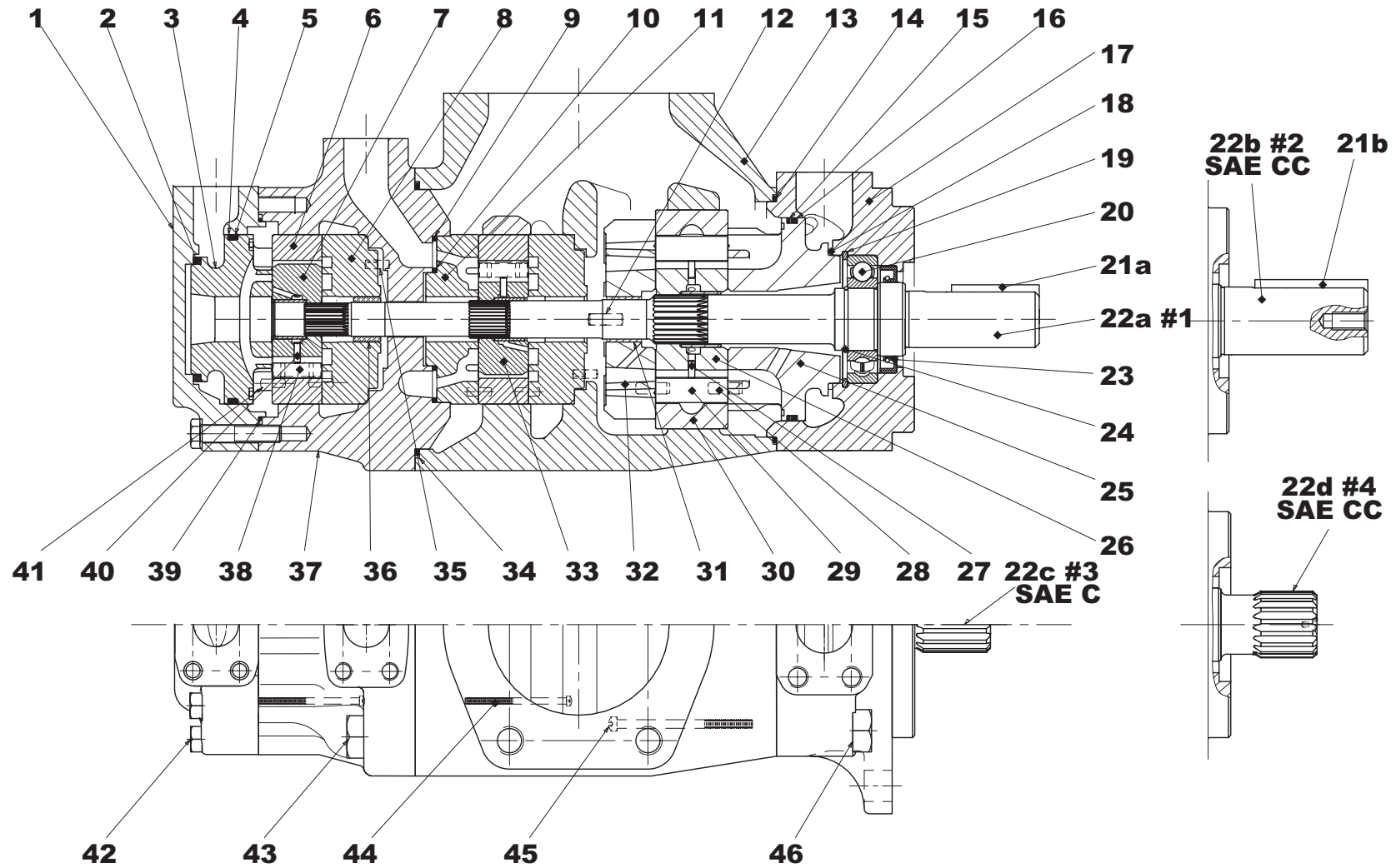

Item Pos. Réf. Pos.	Description Descrizione	Benennung Descripcion	Description		Part N° Teil Nr. Code N° Cod. N° Referencia	Qty Stück Qté Q.tà Cant.	
1	End cap (metric 3/4") <i>Coperchio (metrica 3/4")</i>	Deckel (Metrisch 3/4") <i>Tapa (metrico 3/4")</i>	Chapeau (métrique 3/4")		034.66765	1	
	End cap (UNC 3/4") <i>Coperchio (UNC 3/4")</i>	Deckel (UNC 3/4") <i>Tapa (UNC 3/4")</i>	Chapeau (UNC 3/4")		034.66523	1	
2	Sq. section seal <i>Guarnizione</i>	Dichtring <i>Junta seccion cuadrada</i>	Joint section carrée	CD	691.10229	1	
3	Port plate-pressure <i>Piatto distributore anter.</i>	Steuerplatte <i>Plato distribuidor-presión</i>	Plaque pression	CD	034.66923	1	
4	Sq. section seal <i>Guarnizione</i>	Dichtring <i>Junta seccion cuadrada</i>	Joint section carrée	CD	691.10238	1	
5	Back-up ring <i>Anello anti-estrusione</i>	Stützring <i>Anillo</i>	Bague anti-extrusion	CD	618.00010.3	1	
6	Cam ring 002 <i>Anello camma 002</i>	Hubring 002 <i>Aro volumetrico 002</i>	Came 002	BC	034.66909	2	
	Cam ring 003 <i>Anello camma 003</i>	Hubring 003 <i>Aro volumetrico 003</i>	Came 003	BC	034.66910	2	
	Cam ring 004 <i>Anello camma 004</i>	Hubring 004 <i>Aro volumetrico 004</i>	Came 004	BC	034.66911	2	
	Cam ring 005 <i>Anello camma 005</i>	Hubring 005 <i>Aro volumetrico 005</i>	Came 005	BC	034.66912	2	
	Cam ring 006 <i>Anello camma 006</i>	Hubring 006 <i>Aro volumetrico 006</i>	Came 006	BC	034.66913	2	
	Cam ring 007 <i>Anello camma 007</i>	Hubring 007 <i>Aro volumetrico 007</i>	Came 007	BC	034.67063	2	
	Cam ring 008 <i>Anello camma 008</i>	Hubring 008 <i>Aro volumetrico 008</i>	Came 008	BC	034.66914	2	
	Cam ring 009 <i>Anello camma 009</i>	Hubring 009 <i>Aro volumetrico 009</i>	Came 009	BC	034.67383	2	
	Cam ring 010 <i>Anello camma 010</i>	Hubring 010 <i>Aro volumetrico 010</i>	Came 010	BC	034.66915	2	
	Cam ring 011 <i>Anello camma 011</i>	Hubring 011 <i>Aro volumetrico 011</i>	Came 011	BC	034.67461	2	
	Cam ring 012 <i>Anello camma 012</i>	Hubring 012 <i>Aro volumetrico 012</i>	Came 012	BC	034.67032	2	
	Cam ring 014 <i>Anello camma 014</i>	Hubring 014 <i>Aro volumetrico 014</i>	Came 014	BC	034.67409	2	
	Cam ring 015 <i>Anello camma 015</i>	Hubring 015 <i>Aro volumetrico 015</i>	Came 015	BC	034.67034	2	
	7	Rotor ass'y <i>Insieme rotore</i>	Rotor <i>Conjunto rotor</i>	Rotor ass.	C	S24.49820	1
	8	Port plate-rear <i>Piatto distributore post</i>	Steuerplatte <i>Plato distribuidor trasero</i>	Plaque arrière	BCMNI	034.66922	2
9	Sq. section seal <i>Guarnizione</i>	Dichtring <i>Junta seccion cuadrada</i>	Joint section carrée	BD	691.10153	1	
10	Sq. section seal <i>Guarnizione</i>	Dichtring <i>Junta seccion cuadrada</i>	Joint section carrée	BD	691.10137	1	
11	Port plate-pressure <i>Piatto distributore anter.</i>	Steuerplatte <i>Plato distribuidor-presión</i>	Plaque pression	B	034.67060	1	
12	Dowel pin <i>Spina</i>	Zentrierstift <i>Pasador</i>	Goupille	AJKL	323.82004	1	

Item Pos. Réf. Pos.	Description Descrizione	Benennung Descripcion	Description		Part N° Teil Nr. Code N° Cod. N° Referencia	Qty Stück Qté Q.tà Cant.
13	Housing (standard) (metric) <i>Corpo (standard) (metrico)</i>	Gehäuse (Standard) (Metrisch) <i>Cuerpo (estándar) (metrica)</i>	Carter (standard) (métrique)		034.66763	1
	Housing (standard) (UNC) <i>Corpo (standard) (UNC)</i>	Gehäuse (Standard) (UNC) <i>Cuerpo (estándar) (UNC)</i>	Carter (standard) (UNC)		034.66497	1
14	Sq. section seal <i>Guarnizione</i>	Dichtring <i>Junta seccion cuadrada</i>	Joint section carrée	AD	671.10159	1
15	Back-up ring <i>Anello anti-estrusione</i>	Stützring <i>Anillo</i>	Bague anti-extrusion	AD	618.00011.3	1
16	Sq. section seal <i>Guarnizione</i>	Dichtring <i>Junta seccion cuadrada</i>	Joint section carrée	AD	691.10244	1
17	Mounting cap (metric) <i>Coperchio (metrica)</i>	Deckel (Metrisch) <i>Tapa de montage 1" (metrico)</i>	Chapeau de montage (métrique)		034.66748	1
	Mounting cap (UNC) <i>Coperchio (UNC)</i>	Deckel (UNC) <i>Tapa de montage (UNC)</i>	Chapeau de montage (UNC)		034.66495	1
18	Sq. section seal <i>Guarnizione</i>	Dichtring <i>Junta seccion cuadrada</i>	Joint section carrée	AD	691.10232	1
19	Retaining ring <i>Anello elastico</i>	Sicherungsring <i>Anillo de retención</i>	Circlips		356.32283	1
20	Ball bearing <i>Cuscinetto a sfere</i>	Kugellager <i>Cojinete de bolas</i>	Roulement à billes	EFGH	230.00207	1
21a	Key (code 1) <i>Chiavetta (codice 1)</i>	Paßfeder (Typ 1) <i>Chaveta (codigo 1)</i>	Clavette (code 1)	E	034.19579	1
21b	Key (code 2) <i>Chiavetta (codice 2)</i>	Paßfeder (Typ 2) <i>Chaveta (codigo 2)</i>	Clavette (code 2)	F	034.66981	1
22a	Shaft (keyed) (code1) <i>Albero a chiavetta (codice 1)</i>	Welle für Paßfeder (Typ 1) <i>Eje chaveteado (codigo 1)</i>	Arbre à clavette (code 1)	E	034.66500	1
22b	Shaft (keyed) (code 2) (SAE CC) <i>Albero a chiavetta (codice 2) (SAE CC)</i>	Welle für Paßfeder (Typ 2) (SAE CC) <i>Eje chaveteado (codigo 2) (SAE CC)</i>	Arbre à clavette (code 2) (SAE CC)	F	034.66513	1
22c	Shaft (splined) (code 3) (SAE C) <i>Albero a scanalato (codice 3) (SAE C)</i>	Vielkeilwelle (Typ 3) (SAE C) <i>Eje estriado (codigo 3) (SAE C)</i>	Arbre à cannelures (code 3) (SAE C)	G	034.66511	1
22d	Shaft (splined) (code 4) (SAE CC) <i>Albero scanalato (codice 4) (SAE CC)</i>	Vielkeilwelle (Typ 4) (SAE CC) <i>Eje estriado (codigo 4) (SAE CC)</i>	Arbre à cannelures (code 4) (SAE CC)	H	034.66514	1
23	Shaft seal (S1 - 0,7 bar) <i>Paraolio (S1 - 0,7 bar)</i>	Simmerring (S1 - 0,7 bar) <i>Reten eje (S1 - 0,7 bar)</i>	Joint d'arbre (S1 - 0,7 bar)	D	620.82064	1
	Shaft seal (S4 - S5 - 7 bar) <i>Paraolio (S4 - S5 - 7 bar)</i>	Simmerring (S4 - S5 - 7 bar) <i>Reten eje (S4 - S5 - 7 bar)</i>	Joint d'arbre (S4 - S5 - 7 bar)	D	620.82072	1
24	Round section ring <i>Anello elastico</i>	Sicherungsring <i>Anillo tórico</i>	Anneau	EFGH	034.70853	1
25	Port plate-pressure (Except cam rings 045 - 050) <i>Piatto distributore anter. (Eccetto anello camma 045-050)</i>	Steuerplatte (außer Hubringe 045-050) <i>Plato distribuidor-presión (Excepto los aros 045-050)</i>	Plaque pression (Excepté cames 045 - 050)	A	034.67479	1
	Port plate-pressure C.C.W. (Only cam rings 045 - 050) <i>Piatto distributore anter.antioraria (Solo anello camma 045-050)</i>	Steuerplatte Linkslauf (nur Hubringe 045-050) <i>Plato distribuidor-presión giro I (Solo los aros 045-050)</i>	Plaque press. rot. gauche (Seul. cames 045-050)	A	034.67113	1
	Port plate-pressure C.W. (Only cam rings 045 - 050) <i>Piatto distributore anter. Oraria (Solo anello camma 045-050)</i>	Steuerplatte Rechtslauf (nur Hubringe 045-050) <i>Plato distribuidor-presión giro D (Solo los aros 045-050)</i>	Plaque press. rot. droite (Seul. cames 045-050)	A	034.67111	1
	Rotor ass'y (Except cam rings 045 - 050) <i>Insieme rotore (Eccetto anello camma 045-050)</i>	Rotor (außer Hubringe 045-050) <i>Conjunto rotor Excepto los aros 045-050)</i>	Rotor ass. (Excepté cames 045 - 050)	A	S24.73783	1
26	Rotor ass'y (Only cam ring 045 - 050) <i>Insieme rotore (Solo anello camma 045-050)</i>	Rotor (nur Hubringe 045-050) <i>Conjunto rotor (Solo los aros 045-050)</i>	Rotor ass. (Seul. cames 045-050)	A	S24.10121	1
	Pin-vane holdout (Except cam rings 045 - 050) <i>Pistoncino di sostentamento (Eccetto anello camma 045-050)</i>	Stößel (außer Hubringe 045-050) <i>Espiga empuje paleta (Excepto los aros 045-050)</i>	Poussoir de palette (Excepté cames 045 - 050)	A	034.59098	12

Item Pos. Réf. Pos. Pos.	Description Descrizione	Benennung Descripcion	Description		Part N° Teil Nr. Code N° Cod. N° Referencia	Qty Stück Qté Q.tà Cant.
27	Pin-vane holdout (Only cam ring 045 - 050) <i>Pistoncino di sostentamento (Solo anello camma 045-050)</i>	Stössel (nur Hubringe 045-050) <i>Espiga empuje paleta (Solo los aros 045-050)</i>	Poussoir de palette (Seul. cames 045-050)	A	034.59130	10
28	Dowel pin <i>Spina</i>	Zentrierstift <i>Pasador</i>	Goupille	A	324.21612	2
29	Vane (Except cam rings 045 - 050) <i>Paletta (Eccetto anello camma 045-050)</i>	Flügel (außer Hubringe 045-050) <i>Paleta (Excepto los aros 045-050)</i>	Palette (Excepté cames 045 - 050)	A	034.67453	12
	Vane (Only cam ring 045 - 050) <i>Paletta (Solo anello camma 045-050)</i>	Flügel (nur Hubringe 045-050) <i>Paleta (Solo los aros 045-050)</i>	Palette (Seul. cames 045-050)	A	034.53588	10
30	Cam ring 014 <i>Anello camma 014</i>	Hubring 014 <i>Aro volumetrico 014</i>	Came 014	A	034.67469	1
	Cam ring 017 <i>Anello camma 017</i>	Hubring 017 <i>Aro volumetrico 017</i>	Came 017	A	034.67470	1
	Cam ring 020 <i>Anello camma 020</i>	Hubring 020 <i>Aro volumetrico 020</i>	Came 020	A	034.67159	1
	Cam ring 022 <i>Anello camma 022</i>	Hubring 022 <i>Aro volumetrico 022</i>	Came 022	A	034.67482	1
	Cam ring 024 <i>Anello camma 024</i>	Hubring 024 <i>Aro volumetrico 024</i>	Came 024	A	034.67158	1
	Cam ring 028 <i>Anello camma 028</i>	Hubring 028 <i>Aro volumetrico 028</i>	Came 028	A	034.67157	1
	Cam ring 031 <i>Anello camma 031</i>	Hubring 031 <i>Aro volumetrico 031</i>	Came 031	A	034.67156	1
	Cam ring 035 <i>Anello camma 035</i>	Hubring 035 <i>Aro volumetrico 035</i>	Came 035	A	034.67155	1
	Cam ring 038 <i>Anello camma 038</i>	Hubring 038 <i>Aro volumetrico 038</i>	Came 038	A	034.67154	1
	Cam ring 042 <i>Anello camma 042</i>	Hubring 042 <i>Aro volumetrico 042</i>	Came 042	A	034.67153	1
	Cam ring 045 <i>Anello camma 045</i>	Hubring 045 <i>Aro volumetrico 045</i>	Came 045	A	034.59131	1
	Cam ring 050 <i>Anello camma 050</i>	Hubring 050 <i>Aro volumetrico 050</i>	Came 050	A	034.66737	1
31	Bush <i>Bussola</i>	Buchse <i>Cojinete de fricción</i>	Bague	A	034.70868	1
32	Port plate-rear (Except cam rings 045 - 050) <i>Piatto distributore post. (Eccetto anello camma 045-050)</i>	Steuerplatte (außer Hubringe 045-050) <i>Plato distribuidor trasero ((Excepto los aros 045-050)</i>	Plaque arrière (Excepté cames 045 - 050)	AL	034.67478	1
	Port plate-rear C.C.W. (Only cam ring 045 - 050) <i>Piatto distributore post. Antioraria (Solo anello camma 045-050)</i>	Steuerplatte Linkslauf (nur Hubringe 045-050) <i>Plato distribuidor trasero giro I (Solo los aros 045-050)</i>	Plaque arr. rotation gauche (Seul. cames 045-050)	AK	034.67114	1
	Port plate-rear C.W. (Only cam ring 045 - 050) <i>Piatto distributore post. Oraria (Solo anello camma 045-050)</i>	Steuerplatte Rechtslauf (nur Hubringe 045-050) <i>Plato distribuidor trasero giro D (Solo los aros 045-050)</i>	Plaque arr. rotation droite (Seul. cames 045-050)	AJ	034.67112	1
33	Rotor ass'y <i>Insieme rotore</i>	Rotor <i>Conjunto rotor</i>	Rotor ass.	B	S24.51722	1
34	Sq. section seal <i>Guarnizione</i>	Dichtring <i>Junta seccion cuadrada</i>	Joint section carrée	BD	691.10256	1
35	Dowel pin <i>Spina</i>	Zentrierstift <i>Pasador</i>	Goupille	BCMN	323.82010	2
36	Bush <i>Bussola</i>	Buchse <i>Cojinete de fricción</i>	Bague	C	034.59412	1
37	Port block UNC <i>Corpo bocche UNC</i>	Anschlußblock UNC <i>Bloque distribuidor UNC</i>	Palier UNC		034.66499	1

Item Pos. Réf. Pos. Pos.	Description Descrizione	Benennung Descripcion	Description		Part N° Teil Nr. Code N° Cod. N° Referencia	Qty Stück Qté Q.tà Cant.
37	Port block metric <i>Corpo bocche metrica</i>	Anschlußblock Metrich <i>Bloque distribuidor metrico</i>	Palier métrique		034.66764	1
38	Vane <i>Paletta</i>	Flügel <i>Paleta</i>	Palette	BC	034.66917	24
39	Sq. section seal <i>Guarnizione</i>	Dichtring <i>Junta seccion cuadrada</i>	Joint section carrée	CD	671.10156	1
40	Pin-vane holdout <i>Pistoncino di sostentamento</i>	Stößel <i>Espiga empuje paleta</i>	Poussoir de palette	BC	034.66991	24
41	Dowel pin <i>Spina</i>	Zentrierstift <i>Pasador</i>	Goupille	BC	324.21208	4
42	Screw <i>Vite</i>	Schraube <i>Tornille</i>	Vis		306.40111	7
43	Screw <i>Vite</i>	Schraube <i>Tornille</i>	Vis		306.40154	4
44	Screw <i>Vite</i>	Schraube <i>Tornille</i>	Vis	BC	317.06266	4
45	Screw <i>Vite</i>	Schraube <i>Tornille</i>	Vis	A	317.10320	2
46	Screw <i>Vite</i>	Schraube <i>Tornille</i>	Vis		306.40156	4
	REPAIR KIT KIT DI RICAMBIO	AUSTAUSCH-BAUGRUPPEN CUNJUNTO REPARACION	POCHETTES RECHANGES			
A	Cart. and plate ass'y B14 C.W. (P1) <i>Ins. cart. B14 oraria (P1)</i>	Pumpeneinheit B14 Rechtslauf (P1) <i>Conjunto cart. y platos B14 giro d. (P1)</i>	Cart. et plaque ass. B14 rot. d. (P1)		S24.76312	1
A	Cart. and plate ass'y B14 C.C.W. (P1) <i>Ins. cart. B14 antioraria (P1)</i>	Pumpeneinheit B14 Linkslauf (P1) <i>Conjunto cart. y platos B14 giro i. (P1)</i>	Cart. et plaque ass. B14 rot. g. (P1)		S24.76313	1
A	Cart. and plate ass'y B17 C.W. (P1) <i>Ins. cart. B17 oraria (P1)</i>	Pumpeneinheit B17 Rechtslauf (P1) <i>Conjunto cart. y platos B17 giro d. (P1)</i>	Cart. et plaque ass. B17 rot. d. (P1)		S24.76314	1
A	Cart. and plate ass'y B17 C.C.W. (P1) <i>Ins. cart. B17 antioraria (P1)</i>	Pumpeneinheit B17 Linkslauf (P1) <i>Conjunto cart. y platos B17 giro i. (P1)</i>	Cart. et plaque ass. B17 rot. g. (P1)		S24.76315	1
A	Cart. and plate ass'y B20 C.W. (P1) <i>Ins. cart. B20 oraria (P1)</i>	Pumpeneinheit B20 Rechtslauf (P1) <i>Conjunto cart. y platos B20 giro d. (P1)</i>	Cart. et plaque ass. B20 rot. d. (P1)		S24.76316	1
A	Cart. and plate ass'y B20 C.C.W. (P1) <i>Ins. cart. B20 antioraria (P1)</i>	Pumpeneinheit B20 Linkslauf (P1) <i>Conjunto cart. y platos B20 giro i. (P1)</i>	Cart. et plaque ass. B20 rot. g. (P1)		S24.76317	1
A	Cart. and plate ass'y B22 C.W. (P1) <i>Ins. cart. B22 oraria (P1)</i>	Pumpeneinheit B22 Rechtslauf (P1) <i>Conjunto cart. y platos B22 giro d. (P1)</i>	Cart. et plaque ass. B22 rot. d. (P1)		S24.76318	1
A	Cart. and plate ass'y B22 C.C.W. (P1) <i>Ins. cart. B22 antioraria (P1)</i>	Pumpeneinheit B22 Linkslauf (P1) <i>Conjunto cart. y platos B22 giro i. (P1)</i>	Cart. et plaque ass. B22 rot. g. (P1)		S24.76319	1
A	Cart. and plate ass'y B24 C.W. (P1) <i>Ins. cart. B24 oraria (P1)</i>	Pumpeneinheit B24 Rechtslauf (P1) <i>Conjunto cart. y platos B24 giro d. (P1)</i>	Cart. et plaque ass. B24 rot. d. (P1)		S24.76320	1
A	Cart. and plate ass'y B24 C.C.W. (P1) <i>Ins. cart. B24 antioraria (P1)</i>	Pumpeneinheit B24 Linkslauf (P1) <i>Conjunto cart. y platos B24 giro i. (P1)</i>	Cart. et plaque ass. B24 rot. g. (P1)		S24.76321	1
A	Cart. and plate ass'y B28 C.W. (P1) <i>Ins. cart. B28 oraria (P1)</i>	Pumpeneinheit B28 Rechtslauf (P1) <i>Conjunto cart. y platos B28 giro d. (P1)</i>	Cart. et plaque ass. B28 rot. d. (P1)		S24.76322	1
A	Cart. and plate ass'y B28 C.C.W. (P1) <i>Ins. cart. B28 antioraria (P1)</i>	Pumpeneinheit B28 Linkslauf (P1) <i>Conjunto cart. y platos B28 giro i. (P1)</i>	Cart. et plaque ass. B28 rot. g. (P1)		S24.76323	1

Item Pos. Réf. Pos.	Description <i>Descrizione</i>	Benennung <i>Descripcion</i>	Description	Part N° Teil Nr. Code N° Cod. N° Referencia	Qty Stück Qté Q.tà Cant.
A	Cart. and plate ass'y B31 C.W. (P1) <i>Ins. cart. B31 oraria (P1)</i>	Pumpeneinheit B31 Rechtslauf (P1) <i>Conjunto cart. y platos B31 giro d. (P1)</i>	Cart. et plaque ass. B31 rot. d. (P1)	S24.76324	1
A	Cart. and plate ass'y B31 C.C.W. (P1) <i>Ins. cart. B31 antioraria (P1)</i>	Pumpeneinheit B31 Linkslauf (P1) <i>Conjunto cart. y platos B31 giro i. (P1)</i>	Cart. et plaque ass. B31 rot. g. (P1)	S24.76325	1
A	Cart. and plate ass'y B35 C.W. (P1) <i>Ins. cart. B35 oraria (P1)</i>	Pumpeneinheit B35 Rechtslauf (P1) <i>Conjunto cart. y platos B35 giro d. (P1)</i>	Cart. et plaque ass. B35 rot. d. (P1)	S24.76326	1
A	Cart. and plate ass'y B35 C.C.W. (P1) <i>Ins. cart. B35 antioraria (P1)</i>	Pumpeneinheit B35 Linkslauf (P1) <i>Conjunto cart. y platos B35 giro i. (P1)</i>	Cart. et plaque ass. B35 rot. g. (P1)	S24.76327	1
A	Cart. and plate ass'y B38 C.W. (P1) <i>Ins. cart. B38 oraria (P1)</i>	Pumpeneinheit B38 Rechtslauf (P1) <i>Conjunto cart. y platos B38 giro d. (P1)</i>	Cart. et plaque ass. B38 rot. d. (P1)	S24.76328	1
A	Cart. and plate ass'y B38 C.C.W. (P1) <i>Ins. cart. B38 antioraria (P1)</i>	Pumpeneinheit B38 Linkslauf (P1) <i>Conjunto cart. y platos B38 giro i. (P1)</i>	Cart. et plaque ass. B38 rot. g. (P1)	S24.76329	1
A	Cart. and plate ass'y B42 C.W. (P1) <i>Ins. cart. B42 oraria (P1)</i>	Pumpeneinheit B42 Rechtslauf (P1) <i>Conjunto cart. y platos B42 giro d. (P1)</i>	Cart. et plaque ass. B42 rot. d. (P1)	S24.76330	1
A	Cart. and plate ass'y B42 C.C.W. (P1) <i>Ins. cart. B42 antioraria (P1)</i>	Pumpeneinheit B42 Linkslauf (P1) <i>Conjunto cart. y platos B42 giro i. (P1)</i>	Cart. et plaque ass. B42 rot. g. (P1)	S24.76331	1
A	Cart. and plate ass'y 045 C.W. (P1) <i>Ins. cart. 045 oraria (P1)</i>	Pumpeneinheit 045 Rechtslauf (P1) <i>Conjunto cart. y platos 045 giro d. (P1)</i>	Cart. et plaque ass. 045 rot. d. (P1)	S24.10847	1
A	Cart. and plate ass'y 045 C.C.W. (P1) <i>Ins. cart. 045 antioraria (P1)</i>	Pumpeneinheit 045 Linkslauf (P1) <i>Conjunto cart. y platos 045 giro i. (P1)</i>	Cart. et plaque ass. 045 rot. g. (P1)	S24.10848	1
A	Cart. and plate ass'y 050 C.W. (P1) <i>Ins. cart. 050 oraria (P1)</i>	Pumpeneinheit 050 Rechtslauf (P1) <i>Conjunto cart. y platos 050 giro d. (P1)</i>	Cart. et plaque ass. 050 rot. d. (P1)	S24.40028	1
A	Cart. and plate ass'y 050 C.C.W. (P1) <i>Ins. cart. 050 antioraria (P1)</i>	Pumpeneinheit 050 Linkslauf (P1) <i>Conjunto cart. y platos 050 giro i. (P1)</i>	Cart. et plaque ass. 050 rot. g. (P1)	S24.40029	1
B	Cart. and plate ass'y B02 C.W. (P2) <i>Ins. cart. B02 oraria (P2)</i>	Pumpeneinheit B02 Rechtslauf (P2) <i>Conjunto cart. y platos B02 giro d. (P2)</i>	Cart. et plaque ass. B02 rot. d. (P2)	S24.59709	1
B	Cart. and plate ass'y B02 C.C.W. (P2) <i>Ins. cart. B02 antioraria (P2)</i>	Pumpeneinheit B02 Linkslauf (P2) <i>Conjunto cart. y platos B02 giro i. (P2)</i>	Cart. et plaque ass. B02 rot. g. (P2)	S24.59710	1
B	Cart. and plate ass'y B03 C.W. (P2) <i>Ins. cart. B03 oraria (P2)</i>	Pumpeneinheit B03 Rechtslauf (P2) <i>Conjunto cart. y platos B03 giro d. (P2)</i>	Cart. et plaque ass. B03 rot. d. (P2)	S24.59711	1
B	Cart. and plate ass'y B03 C.C.W. (P2) <i>Ins. cart. B03 antioraria (P2)</i>	Pumpeneinheit B03 Linkslauf (P2) <i>Conjunto cart. y platos B03 giro i. (P2)</i>	Cart. et plaque ass. B03 rot. g. (P2)	S24.59712	1
B	Cart. and plate ass'y B04 C.W. (P2) <i>Ins. cart. B04 oraria (P2)</i>	Pumpeneinheit B04 Rechtslauf (P2) <i>Conjunto cart. y platos B04 giro d. (P2)</i>	Cart. et plaque ass. B04 rot. d. (P2)	S24.59713	1
B	Cart. and plate ass'y B04 C.C.W. (P2) <i>Ins. cart. B04 antioraria (P2)</i>	Pumpeneinheit B04 Linkslauf (P2) <i>Conjunto cart. y platos B04 giro i. (P2)</i>	Cart. et plaque ass. B04 rot. g. (P2)	S24.59714	1
B	Cart. and plate ass'y B05 C.W. (P2) <i>Ins. cart. B05 oraria (P2)</i>	Pumpeneinheit B05 Rechtslauf (P2) <i>Conjunto cart. y platos B05 giro d. (P2)</i>	Cart. et plaque ass. B05 rot. d. (P2)	S24.59715	1
B	Cart. and plate ass'y B05 C.C.W. (P2) <i>Ins. cart. B05 antioraria (P2)</i>	Pumpeneinheit B05 Linkslauf (P2) <i>Conjunto cart. y platos B05 giro i. (P2)</i>	Cart. et plaque ass. B05 rot. g. (P2)	S24.59716	1
B	Cart. and plate ass'y B06 C.W. (P2) <i>Ins. cart. B06 oraria (P2)</i>	Pumpeneinheit B06 Rechtslauf (P2) <i>Conjunto cart. y platos B06 giro d. (P2)</i>	Cart. et plaque ass. B06 rot. d. (P2)	S24.59717	1
B	Cart. and plate ass'y B06 C.C.W. (P2) <i>Ins. cart. B06 antioraria (P2)</i>	Pumpeneinheit B06 Linkslauf (P2) <i>Conjunto cart. y platos B06 giro i. (P2)</i>	Cart. et plaque ass. B06 rot. g. (P2)	S24.59718	1
B	Cart. and plate ass'y B07 C.W. (P2) <i>Ins. cart. B07 oraria (P2)</i>	Pumpeneinheit B07 Rechtslauf (P2) <i>Conjunto cart. y platos B07 giro d. (P2)</i>	Cart. et plaque ass. B07 rot. d. (P2)	S24.59976	1
B	Cart. and plate ass'y B07 C.C.W. (P2) <i>Ins. cart. B07 antioraria (P2)</i>	Pumpeneinheit B07 Linkslauf (P2) <i>Conjunto cart. y platos B07 giro i. (P2)</i>	Cart. et plaque ass. B07 rot. g. (P2)	S24.59977	1
B	Cart. and plate ass'y B08 C.W. (P2) <i>Ins. cart. B08 oraria (P2)</i>	Pumpeneinheit B08 Rechtslauf (P2) <i>Conjunto cart. y platos B08 giro d. (P2)</i>	Cart. et plaque ass. B08 rot. d. (P2)	S24.59719	1

Item Pos. Réf. Pos.	Description <i>Descrizione</i>	Benennung <i>Descripcion</i>	Description	Part N° Teil Nr. Code N° Cod. N° Referencia	Qty Stück Qté Q.tà Cant.
B	Cart. and plate ass'y B08 C.C.W. (P2) <i>Ins. cart. B08 antioraria (P2)</i>	Pumpeneinheit B08 Linkslauf (P2) <i>Conjunto cart. y platos B08 giro i. (P2)</i>	Cart. et plaque ass. B08 rot. g. (P2)	S24.59720	1
B	Cart. and plate ass'y B09 C.W. (P2) <i>Ins. cart. B09 oraria (P2)</i>	Pumpeneinheit B09 Rechtslauf (P2) <i>Conjunto cart. y platos B09 giro d. (P2)</i>	Cart. et plaque ass. B09 rot. d. (P2)	S24.77916	1
B	Cart. and plate ass'y B09 C.C.W. (P2) <i>Ins. cart. B09 antioraria (P2)</i>	Pumpeneinheit B09 Linkslauf (P2) <i>Conjunto cart. y platos B09 giro i. (P2)</i>	Cart. et plaque ass. B09 rot. g. (P2)	S24.59917	1
B	Cart. and plate ass'y B10 C.W. (P2) <i>Ins. cart. B10 oraria (P2)</i>	Pumpeneinheit B10 Rechtslauf (P2) <i>Conjunto cart. y platos B10 giro d. (P2)</i>	Cart. et plaque ass. B10 rot. d. (P2)	S24.59721	1
B	Cart. and plate ass'y B10 C.C.W. (P2) <i>Ins. cart. B10 antioraria (P2)</i>	Pumpeneinheit B10 Linkslauf (P2) <i>Conjunto cart. y platos B10 giro i. (P2)</i>	Cart. et plaque ass. B10 rot. g. (P2)	S24.59722	1
B	Cart. and plate ass'y B11 C.W. (P2) <i>Ins. cart. B11 oraria (P2)</i>	Pumpeneinheit B11 Rechtslauf (P2) <i>Conjunto cart. y platos B11 giro d. (P2)</i>	Cart. et plaque ass. B11 rot. d. (P2)	S24.77918	1
B	Cart. and plate ass'y B11 C.C.W. (P2) <i>Ins. cart. B11 antioraria (P2)</i>	Pumpeneinheit B11 Linkslauf (P2) <i>Conjunto cart. y platos B11 giro i. (P2)</i>	Cart. et plaque ass. B11 rot. g. (P2)	S24.77919	1
B	Cart. and plate ass'y B12 C.W. (P2) <i>Ins. cart. B12 oraria (P2)</i>	Pumpeneinheit B12 Rechtslauf (P2) <i>Conjunto cart. y platos B12 giro d. (P2)</i>	Cart. et plaque ass. B12 rot. d. (P2)	S24.59723	1
B	Cart. and plate ass'y B12 C.C.W. (P2) <i>Ins. cart. B12 antioraria (P2)</i>	Pumpeneinheit B12 Linkslauf (P2) <i>Conjunto cart. y platos B12 giro i. (P2)</i>	Cart. et plaque ass. B12 rot. g. (P2)	S24.59724	1
B	Cart. and plate ass'y B14 C.W. (P2) <i>Ins. cart. B14 oraria (P2)</i>	Pumpeneinheit B14 Rechtslauf (P2) <i>Conjunto cart. y platos B14 giro d. (P2)</i>	Cart. et plaque ass. B14 rot. d. (P2)	S24.77920	1
B	Cart. and plate ass'y B14 C.C.W. (P2) <i>Ins. cart. B14 antioraria (P2)</i>	Pumpeneinheit B14 Linkslauf (P2) <i>Conjunto cart. y platos B14 giro i. (P2)</i>	Cart. et plaque ass. B14 rot. g. (P2)	S24.77921	1
B	Cart. and plate ass'y B15 C.W. (P2) <i>Ins. cart. B15 oraria (P2)</i>	Pumpeneinheit B15 Rechtslauf (P2) <i>Conjunto cart. y platos B15 giro d. (P2)</i>	Cart. et plaque ass. B15 rot. d. (P2)	S24.59725	1
B	Cart. and plate ass'y B15 C.C.W. (P2) <i>Ins. cart. B15 antioraria (P2)</i>	Pumpeneinheit B15 Linkslauf (P2) <i>Conjunto cart. y platos B15 giro i. (P2)</i>	Cart. et plaque ass. B15 rot. g. (P2)	S24.59726	1
C	Cart. and plate ass'y B02 C.W. (P3) <i>Ins. cart. B02 oraria (P3)</i>	Pumpeneinheit B02 Rechtslauf (P3) <i>Conjunto cart. y platos B02 giro d. (P3)</i>	Cart. et plaque ass. B02 rot. d. (P3)	S24.50610	1
C	Cart. and plate ass'y B02 C.C.W. (P3) <i>Ins. cart. B02 antioraria (P3)</i>	Pumpeneinheit B02 Linkslauf (P3) <i>Conjunto cart. y platos B02 giro i. (P3)</i>	Cart. et plaque ass. B02 rot. g. (P3)	S24.50611	1
C	Cart. and plate ass'y B03 C.W. (P3) <i>Ins. cart. B03 oraria (P3)</i>	Pumpeneinheit B03 Rechtslauf (P3) <i>Conjunto cart. y platos B03 giro d. (P3)</i>	Cart. et plaque ass. B03 rot. d. (P3)	S24.50612	1
C	Cart. and plate ass'y B03 C.C.W. (P3) <i>Ins. cart. B03 antioraria (P3)</i>	Pumpeneinheit B03 Linkslauf (P3) <i>Conjunto cart. y platos B03 giro i. (P3)</i>	Cart. et plaque ass. B03 rot. g. (P3)	S24.50613	1
C	Cart. and plate ass'y B04 C.W. (P3) <i>Ins. cart. B04 oraria (P3)</i>	Pumpeneinheit B04 Rechtslauf (P3) <i>Conjunto cart. y platos B04 giro d. (P3)</i>	Cart. et plaque ass. B04 rot. d. (P3)	S24.50614	1
C	Cart. and plate ass'y B04 C.C.W. (P3) <i>Ins. cart. B04 antioraria (P3)</i>	Pumpeneinheit B04 Linkslauf (P3) <i>Conjunto cart. y platos B04 giro i. (P3)</i>	Cart. et plaque ass. B04 rot. g. (P3)	S24.50615	1
C	Cart. and plate ass'y B05 C.W. (P3) <i>Ins. cart. B05 oraria (P3)</i>	Pumpeneinheit B05 Rechtslauf (P3) <i>Conjunto cart. y platos B05 giro d. (P3)</i>	Cart. et plaque ass. B05 rot. d. (P3)	S24.50616	1
C	Cart. and plate ass'y B05 C.C.W. (P3) <i>Ins. cart. B05 antioraria (P3)</i>	Pumpeneinheit B05 Linkslauf (P3) <i>Conjunto cart. y platos B05 giro i. (P3)</i>	Cart. et plaque ass. B05 rot. g. (P3)	S24.50617	1
C	Cart. and plate ass'y B06 C.W. (P3) <i>Ins. cart. B06 oraria (P3)</i>	Pumpeneinheit B06 Rechtslauf (P3) <i>Conjunto cart. y platos B06 giro d. (P3)</i>	Cart. et plaque ass. B06 rot. d. (P3)	S24.50618	1
C	Cart. and plate ass'y B06 C.C.W. (P3) <i>Ins. cart. B06 antioraria (P3)</i>	Pumpeneinheit B06 Linkslauf (P3) <i>Conjunto cart. y platos B06 giro i. (P3)</i>	Cart. et plaque ass. B06 rot. g. (P3)	S24.50619	1
C	Cart. and plate ass'y B07 C.W. (P3) <i>Ins. cart. B07 oraria (P3)</i>	Pumpeneinheit B07 Rechtslauf (P3) <i>Conjunto cart. y platos B07 giro d. (P3)</i>	Cart. et plaque ass. B07 rot. d. (P3)	S24.59907	1
C	Cart. and plate ass'y B07 C.C.W. (P3) <i>Ins. cart. B07 antioraria (P3)</i>	Pumpeneinheit B07 Linkslauf (P3) <i>Conjunto cart. y platos B07 giro i. (P3)</i>	Cart. et plaque ass. B07 rot. g. (P3)	S24.59908	1

Item Pos. Réf. Pos.	Description <i>Descrizione</i>	Benennung <i>Descripcion</i>	Description	Part N° Teil Nr. Code N° Cod. N° Referencia	Qty Stück Qté Q.tà Cant.
C	Cart. and plate ass'y B08 C.W. (P3) Ins. cart. B08 oraria (P3)	Pumpeneinheit B08 Rechtslauf (P3) Conjunto cart. y platos B08 giro d. (P3)	Cart. et plaque ass. B08 rot. d. (P3)	S24.50620	1
C	Cart. and plate ass'y B08 C.C.W. (P3) Ins. cart. B08 antioraria (P3)	Pumpeneinheit B08 Linkslauf (P3) Conjunto cart. y platos B08 giro i. (P3)	Cart. et plaque ass. B08 rot. g. (P3)	S24.50621	1
C	Cart. and plate ass'y B09 C.W. (P3) Ins. cart. B09 oraria (P3)	Pumpeneinheit B09 Rechtslauf (P3) Conjunto cart. y platos B09 giro d. (P3)	Cart. et plaque ass. B09 rot. d. (P3)	S24.72910	1
C	Cart. and plate ass'y B09 C.C.W. (P3) Ins. cart. B09 antioraria (P3)	Pumpeneinheit B09 Linkslauf (P3) Conjunto cart. y platos B09 giro i. (P3)	Cart. et plaque ass. B09 rot. g. (P3)	S24.72697	1
C	Cart. and plate ass'y B10 C.W. (P3) Ins. cart. B10 oraria (P3)	Pumpeneinheit B10 Rechtslauf (P3) Conjunto cart. y platos B10 giro d. (P3)	Cart. et plaque ass. B10 rot. d. (P3)	S24.50622	1
C	Cart. and plate ass'y B10 C.C.W. (P3) Ins. cart. B10 antioraria (P3)	Pumpeneinheit B10 Linkslauf (P3) Conjunto cart. y platos B10 giro i. (P3)	Cart. et plaque ass. B10 rot. g. (P3)	S24.50623	1
C	Cart. and plate ass'y B11 C.W. (P3) Ins. cart. B11 oraria (P3)	Pumpeneinheit B11 Rechtslauf (P3) Conjunto cart. y platos B11 giro d. (P3)	Cart. et plaque ass. B11 rot. d. (P3)	S24.77173	1
C	Cart. and plate ass'y B11 C.C.W. (P3) Ins. cart. B11 antioraria (P3)	Pumpeneinheit B11 Linkslauf (P3) Conjunto cart. y platos B11 giro i. (P3)	Cart. et plaque ass. B11 rot. g. (P3)	S24.76880	1
C	Cart. and plate ass'y B12 C.W. (P3) Ins. cart. B12 oraria (P3)	Pumpeneinheit B12 Rechtslauf (P3) Conjunto cart. y platos B12 giro d. (P3)	Cart. et plaque ass. B12 rot. d. (P3)	S24.59009	1
C	Cart. and plate ass'y B12 C.C.W. (P3) Ins. cart. B12 antioraria (P3)	Pumpeneinheit B12 Linkslauf (P3) Conjunto cart. y platos B12 giro i. (P3)	Cart. et plaque ass. B12 rot. g. (P3)	S24.59010	1
C	Cart. and plate ass'y B14 C.W. (P3) Ins. cart. B14 oraria (P3)	Pumpeneinheit B14 Rechtslauf (P3) Conjunto cart. y platos B14 giro d. (P3)	Cart. et plaque ass. B14 rot. d. (P3)	S24.77174	1
C	Cart. and plate ass'y B14 C.C.W. (P3) Ins. cart. B14 antioraria (P3)	Pumpeneinheit B14 Linkslauf (P3) Conjunto cart. y platos B14 giro i. (P3)	Cart. et plaque ass. B14 rot. g. (P3)	S24.77176	1
C	Cart. and plate ass'y B15 C.W. (P3) Ins. cart. B15 oraria (P3)	Pumpeneinheit B15 Rechtslauf (P3) Conjunto cart. y platos B15 giro d. (P3)	Cart. et plaque ass. B15 rot. d. (P3)	S24.59011	1
C	Cart. and plate ass'y B15 C.C.W. (P3) Ins. cart. B15 antioraria (P3)	Pumpeneinheit B15 Linkslauf (P3) Conjunto cart. y platos B15 giro i. (P3)	Cart. et plaque ass. B15 rot. g. (P3)	S24.59012	1
D	Seal kit (S1 - 0,7 bar) <i>Serie guarnizioni (S1 - 0,7 bar)</i>	Dichtringsatz (S1 - 0,7 bar) <i>Juego de juntas (S1 - 0,7 bar)</i>	Pochette de joint (S1 - 0,7 bar)	S24.25575	1
D	Seal kit (S4 - 7 bar) <i>Serie guarnizioni (S4 - 7 bar)</i>	Dichtringsatz (S4 - 7 bar) <i>Juego de juntas (S4 - 7 bar)</i>	Pochette de joint (S4 - 7 bar)	S24.25575.4	1
D	Seal kit (S5 - 7 bar) <i>Serie guarnizioni (S5 - 7 bar)</i>	Dichtringsatz (S5 - 7 bar) <i>Juego de juntas (S5 - 7 bar)</i>	Pochette de joint (S5 - 7 bar)	S24.25575.5	1
E	Shaft and bearing ass'y (code 1) <i>Ins. albero (codice 1)</i>	Baugruppe (Welle u. Lager) (Typ 1) <i>Conjunto eje cojinete (codigo 1)</i>	Arbre et roulement ass. (code 1)	S24.25571	1
F	Shaft and bearing ass'y (code 2) <i>Ins. albero (codice 2)</i>	Baugruppe (Welle u. Lager) (Typ 2) <i>Conjunto eje cojinete (codigo 2)</i>	Arbre et roulement ass. (code 2)	S24.25572	1
G	Shaft and bearing ass'y (code 3) <i>Ins. albero (codice 3)</i>	Baugruppe (Welle u. Lager) (Typ 3) <i>Conjunto eje cojinete (codigo 3)</i>	Arbre et roulement ass. (code 3)	S24.25573	1
H	Shaft and bearing ass'y (code 4) <i>Ins. albero (codice 4)</i>	Baugruppe (Welle u. Lager) (Typ 4) <i>Conjunto eje cojinete (codigo 4)</i>	Arbre et roulement ass. (code 4)	S24.25574	1
J	Port plate rear ass'y C.W. (P1) (Only cam ring 045 - 050) <i>Ins. piatto dist. post. Oraria (P1)</i> <i>(Solo anello camma 045-050)</i>	Steuerplatte Rechtslauf (P1) (nur Hubringe 045-050) <i>Conj. plato dist. trasero giro D (P1)</i> <i>(Solo los aros 045-050)</i>	Plaque arrière ass. rot. droite (P1) (Seulement comes 045-050)	S24.63709	1
K	Port plate rear ass'y C.C.W. (P1) (Only cam ring 045 - 050) <i>Ins. piatto dist. post. Antioraria (P1)</i> <i>(Solo anello camma 045-050)</i>	Steuerplatte Linkslauf (P1) (nur Hubringe 045-050) <i>Conj. plato dist. trasero giro I (P1)</i> <i>(Solo los aros 045-050)</i>	Plaque arrière ass. rot. gauche (P1) (Seulement comes 045-050)	S24.63710	1

Model Code

Typenschlüssel

Désignation - type

Model number

T67DBB series - SAE C 2 bolts
Mounting flange J744

One letter can be added to specify special parts in series

Cam ring for P1

(Volumetric displacement) (ml/rev.)

B14 = 44,0
B17 = 55,0
B20 = 66,0
B22 = 70,3

Cam ring for P2

(Volumetric displacement) (ml/rev.)

B02 = 5,8
B03 = 9,8
B04 = 12,8
B05 = 15,9
B06 = 19,8

Cam ring for P3

(Volumetric displacement) (ml/rev.)

B02 = 5,8
B03 = 9,8
B04 = 12,8
B05 = 15,9
B06 = 19,8

Type of shaft

1 = keyed (no SAE)
2 = keyed (SAE CC)
3 = splined (SAE C)
4 = splined (SAE CC)

Direction of rotation

R = Clockwise
L = Counter-clockwise

Porting combination

00 = standard

Design letter

Seal class

1 = S1 - BUNA N
4 = S4 - EPDM
5 = S5 - VITON

Mounting w/connection variables

4 bolts SAE flange (J518)

Code	01	M1
SAE	UNC	Metric
SAE	P1 = 1"1/4 - P2 = 1"	
	P3 = 3/4" - S = 4"	

Modifications

Typenbezeichnung :

Baureihe T67DBB - SAE C 2 Loch
Montageflansch, J744

Optionen

Hubring P1

(Geometrisches Fördervolumen) (cm³/U)

B24 = 81,1
B28 = 90,0
B31 = 99,2
B35 = 113,4

Hubring P2

(Geometrisches Fördervolumen) (cm³/U)

B07 = 22,5
B08 = 24,9
B09 = 28,0
B10 = 31,8

Hubring P3

(Geometrisches Fördervolumen) (cm³/U)

B07 = 22,5
B08 = 24,9
B09 = 28,0
B10 = 31,8

Art der Welle

1 = Paßfederwelle (no SAE)
2 = Paßfederwelle (SAE CC)
3 = Vielkeilwelle (SAE C)
4 = Vielkeilwelle (SAE CC)

Drehrichtung

R = Rechtslauf
L = Linkslauf

Lage der Anschlüsse

00 = standard

Ausführungsbuchstabe

Dichtungsklasse

1 = S1 - BUNA N
4 = S4 - EPDM
5 = S5 - VITON

Gehäuse-Anschlußgröße

SAE Flansch (J518)

Type	01	M1
SAE	UNC	Metrisch
SAE	P1 = 1"1/4 - P2 = 1"	
	P3 = 3/4" - S = 4"	

Modifikationen

Numéro du modèle :

T67DBB - **B38** - **B14** - **B08** - **1** **R** **00** - **B** **1** - **M1** - ..

Série T67DBB - SAE C 2 trous
Bride de montage J744

Une lettre peut être ajoutée pour spécifier les pièces spéciales dans la série.

Came pour P1

(Cylindrée théorique) (cm³/tr)

B38 = 120,6
B42 = 137,5
045 = 145,7
050 = 158,0

Came pour P2

(Cylindrée théorique) (cm³/tr)

B11 = 35,0
B12 = 41,0
B14 = 45,0
B15 = 50,0

Came pour P3

(Cylindrée théorique) (cm³/tr)

B11 = 35,0
B12 = 41,0
B14 = 45,0
B15 = 50,0

Type d'arbre

1 = à clavette (no SAE)
2 = à clavette (SAE CC)
3 = à cannelures (SAE C)
4 = à cannelures (SAE CC)

Sens de rotation

R = à droite
L = à gauche

Combinaison des orifices

00 = standard

Conception

Classe de joint

1 = S1 - BUNA N
4 = S4 - EPDM
5 = S5 - VITON

Option sur orifices

Bride SAE 4 trous (J518)

Code	01	M1
SAE	UNC	Métrique
SAE	P1 = 1"1/4 - P2 = 1"	
	P3 = 3/4" - S = 4"	

Modifications

Designazione

Clave de designación

Sigla :

Serie T67DBB - SAE C 2 fori
Flangia di montaggio J744

Una lettera può essere aggiunta per specificare parti speciali nella serie

Tipo di cartuccia P1

(Cilindrata) (ml/giro)
B14 = 44,0 B24 = 81,1
B17 = 55,0 B28 = 90,0
B20 = 66,0 B31 = 99,2
B22 = 70,3 B35 = 113,4

Tipo di cartuccia P2

(Cilindrata) (ml/giro)
B02 = 5,8 B07 = 22,5
B03 = 9,8 B08 = 24,9
B04 = 12,8 B09 = 28,0
B05 = 15,9 B10 = 31,8
B06 = 19,8

Tipo di cartuccia P3

(Cilindrata) (ml/giro)
B02 = 5,8 B07 = 22,5
B03 = 9,8 B08 = 24,9
B04 = 12,8 B09 = 28,0
B05 = 15,9 B10 = 31,8
B06 = 19,8

Tipo di albero

1 = a chiavetta (no SAE)
2 = a chiavetta (SAE CC)
3 = scanalato (SAE C)
4 = scanalato (SAE CC)

Senso di rotazione

R = Orario
L = Antiorario

Orientamento delle bocche

00 = standard

Disegno

Tipo di guarnizioni

1 = S1 - BUNA N
4 = S4 - EPDM
5 = S5 - VITON

Dimensioni delle bocche

Flangia SAE 4 drenaggio (J518c)

Codice	01	M1
SAE	UNC	Metrica
SAE	P1 = 1"1/4 - P2 = 1" P3 = 3/4" - S = 4"	

Referencia modelo :

Serie T67DBB - SAE C 2 taladros
Brida de montaje J744

Una letra puede ser añadida para especificar piezas especiales en la serie

Aro volumetrico para P1

(Cilindrada) (ml/rev)
B38 = 120,6
B42 = 137,5
045 = 145,7
050 = 158,0

Aro volumetrico para P2

(Cilindrada) (ml/rev)
B11 = 35,0
B12 = 41,0
B14 = 45,0
B15 = 50,0

Aro volumetrico para P3

(Cilindrada) (ml/rev)
B11 = 35,0
B12 = 41,0
B14 = 45,0
B15 = 50,0

Tipo de eje

1 = chaveteado (no SAE)
2 = chaveteado (SAE CC)
3 = estriado (SAE C)
4 = estriado (SAE CC)

Sentido de giro

R = Derecha
L = Izquierda

Posición de bocas

00 = estándar

Letra de diseño

Clase de juntas

1 = S1 - BUNA N
4 = S4 - EPDM
5 = S5 - VITON

Opciones de las bocas

Flange SAE 4 fori (J518c)

Codigo	01	M1
SAE	UNC	Metrica
SAE	P1 = 1"1/4 - P2 = 1" P3 = 3/4" - S = 4"	

Modifiche

Modificaciones

T67DBB . - **B38** - **B14** - **B08** - **1** **R** **00** - **B** **1** - **M1** - ..

P1

P2

P3