

# DENISON HYDRAULICS

## VENUS Controller

### 020-14103



Publ. 9-AM651-A

**DENISON** Hydraulics

Internet: <http://www.denisonhydraulics.com>  
Email: [denison@denisonhydraulics.com](mailto:denison@denisonhydraulics.com)

**TYPICAL CHARACTERISTICS**

The Absolute Maximum ratings are for reference only. Operating this device in these regions may cause this unit to fail.

**INPUTS****OUTPUTS**

Pulse Width Modulation (PWM) with current feedback and short circuit protection.

**Miscellaneous**

Specifications	Nominal	Absolute Maximum
<b>Power Supply</b>	12-24VDC @ 0.2 Amps + coil current	34VDC
<b>Local Command Set Digitally</b>	-100% - +100%	
<b>Main input Commands</b>	±10VDC ±5VDC ±0-20mA 4-20mA	±50VDC ±50VDC ±30mA DC +30mA DC
<b>Auxiliary Input Command</b>	±5VDC	±50VDC
<b>Analog Feedback Inputs</b>	±10VDC ±5VDC ±0-20mA 4-20mA	±50VDC ±50VDC ±30mA DC +30mA DC
<b>Horsepower Limiting Inputs</b>	0-1Amp AC 4-20mA DC 0-10V DC	2 Amps AC <u>continuous</u> +30mA DC ±50VDC
<b>Differential Encoder Inputs</b>	5VDC	±15VDC
<b>Single Ended Encoder Inputs</b>	5VDC	±25VDC
<b>Magnetic Pickup</b>	97mVAC RMS	70VAC RMS
<b>Proximity Probe</b>	5VDC	±25VDC
<b>Digital Feedback Frequency Range</b>	21 - 100,000Hz	
<b>Emergency Stop</b>	12 - 24VDC	±50VDC
<b>Reverse CMD</b>	12 - 24VDC	±50VDC
<b>Soft Stop</b>	12 - 24VDC	±50VDC
<b>Ramp 1 / Ramp 2</b>	12 - 24VDC	±50VDC
<b>Main / Aux Command</b>	12 - 24VDC	±50VDC
<b>Output Driver Current Ranges</b>	±0.5ADC ±1.0ADC ±1.5ADC ±3.0ADC	±6.0ADC ±6.0ADC ±6.0ADC ±6.0ADC
<b>PWM Frequency Ranges</b>	100Hz 140Hz 200Hz 2000Hz	
<b>Encoder Excitation</b>	5VDC	30mADC
<b>Potentiometer Excitation</b>	+5VDC -5VDC	10mADC 10mADC
<b>Ramp 1 &amp; Ramp 2</b>		
Set with Terminal S20-14125	0-90 Seconds	
Set with PC Program S20-14131	0-300 Seconds	
<b>Soft Stop</b>		
Activated ramp rate	0-60 Seconds	
De-activated ramp rate	0-60 Seconds	
<b>Operating Temperature</b>	0 <sup>o</sup> to 70 <sup>o</sup> C	
<b>User Interface</b>	RS232 9 pin Female D type connector	
<b>DIN RAIL Mounting</b>	35mm x 7.5mm 35mm x 15mm	
<b>Dimensions, in. (mm)</b>	4.33 (110) H 5.82 (149) W 2.85 (75) D	

**Note:** New revisions are shown underlined.

Pages are marked revised where changes have been made.

MINIMUM HARDWARE REQUIREMENTS

**NOTICE:**

The chassis GND, terminal 24, is connected to the internal shield and must be connected to an Earth / Safety Ground for proper device shielding.

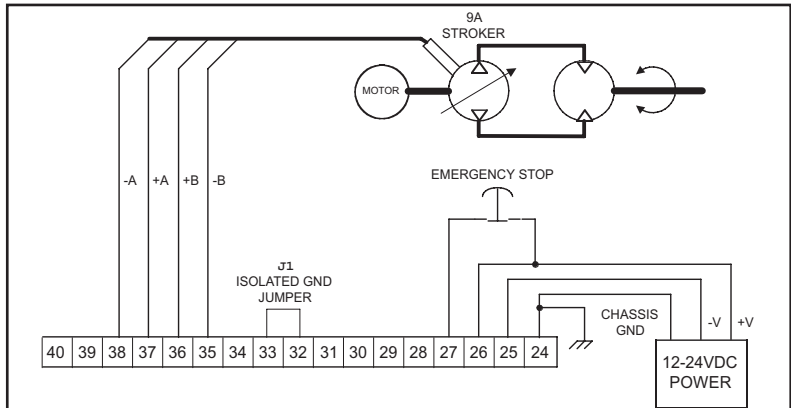

The Emergency Stop input, terminal 27, must be connected to 12-24VDC to allow Venus outputs to function.

Terminals 27 and 32 are isolated and require a Ground (GND) reference to operate properly. This drawing shows the circuit configuration.

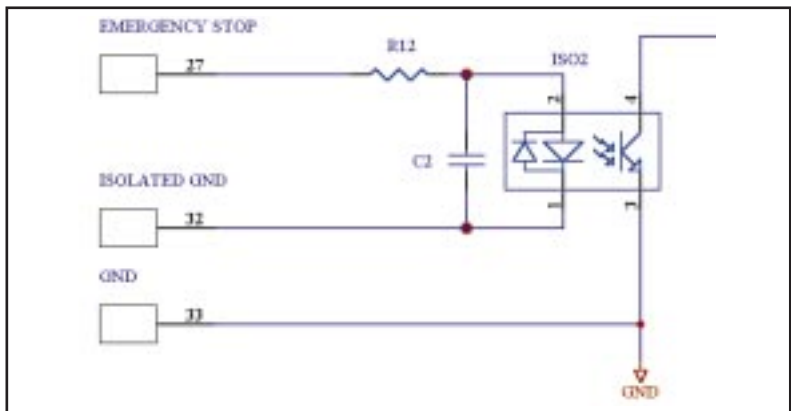

The output terminals are configured such that with a positive input command Coil A will be energized.

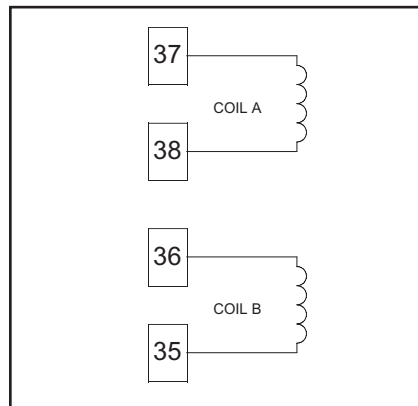

## ALWAYS

- Read this data sheet completely **BEFORE** starting.
- Mount this controller and any electronic control device in an electrically conductive metal enclosure.
- Connect the enclosure to an 'ELECTRICALLY CLEAN' Earth Ground with a minimum wire size of 12 gauge.
- Keep High Voltage AC power lines separate from Low Voltage DC control signals, current loops, feedback signals (voltage, current and frequency types) and supply cables.
- Use shielded cable for all control signals, feedback signals and coil outputs.
- Connect all shields to the enclosure for proper termination and leave the other end of the shield unconnected.
- Connect terminal #24 on the controller to the enclosure for proper grounding.
- Check all connections to and from the controller to ensure correct connections and tightness of the terminals.
- Ensure that the supply voltage is correct, 'ELECTRICALLY CLEAN' and stable.
- Contact DENISON Hydraulics if unsure of installation.

## NEVER

- Never attempt to use this unit if you are unsure of the connections or expected operation.
- Never use a power supply that is marginal or under rated for the current requirements of the coil being driven.
- Never use this unit in areas of intense RF radiation without adequate shielding precautions.

## WHEREVER POSSIBLE

- Leave this unit powered and use the Emergency Stop or Soft Stop inputs to turn off the outputs when the hydraulic system is not powered.

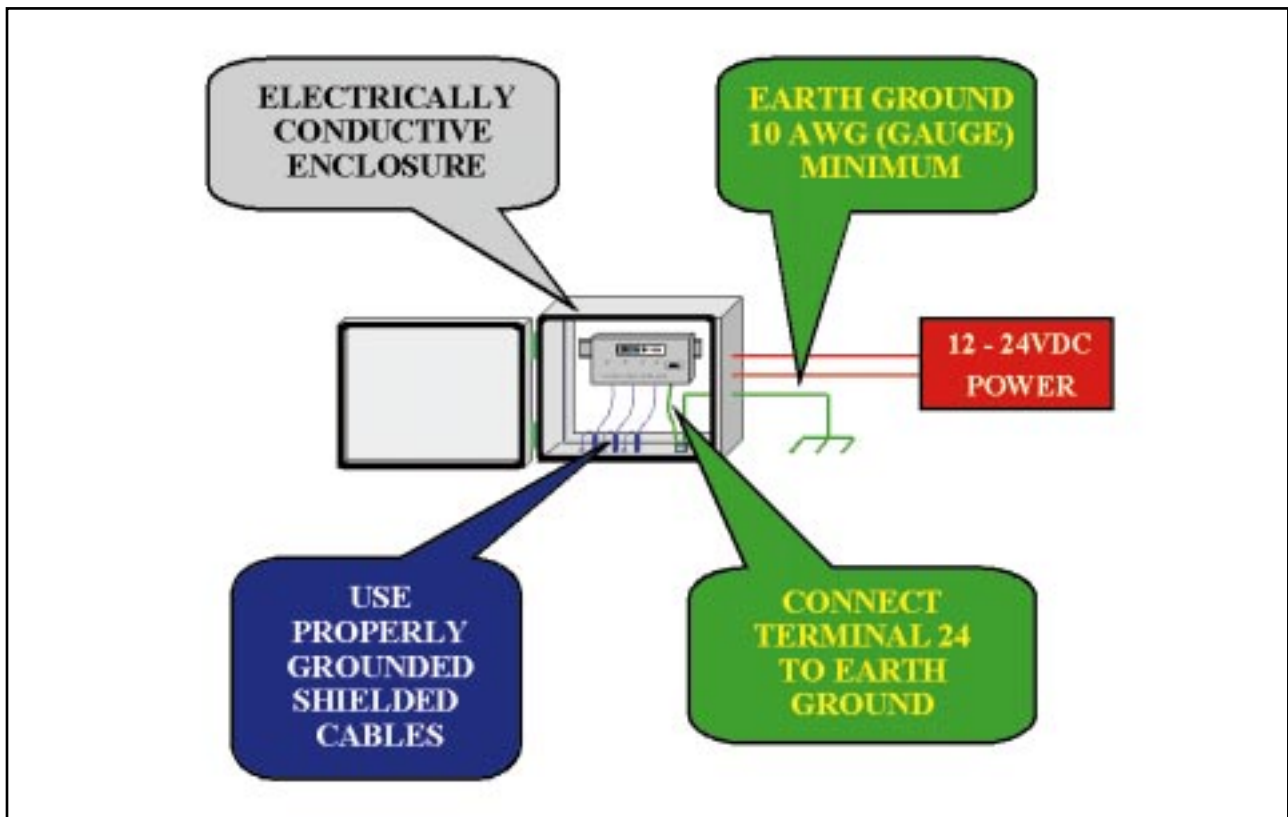

The controller can communicate to the user by two different methods.

The Venus Controller requires configuration before the unit will function properly. System parameters must be programmed by the user to configure the controller to the application.

**METHOD 1**



Method 1: The hand held terminal, S20-14125, will prompt the user through a menu system to setup Venus. No other programming tools are required. Refer to page 15 for operating instructions.

**METHOD 2**

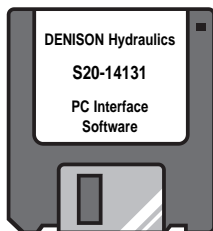

Method 2: A PC computer interface using the S20-14131 Interface program, VDOS, and a portable computer. The S20-14131 program is DOS based and is compatible with Windows 3.x and Windows 95.

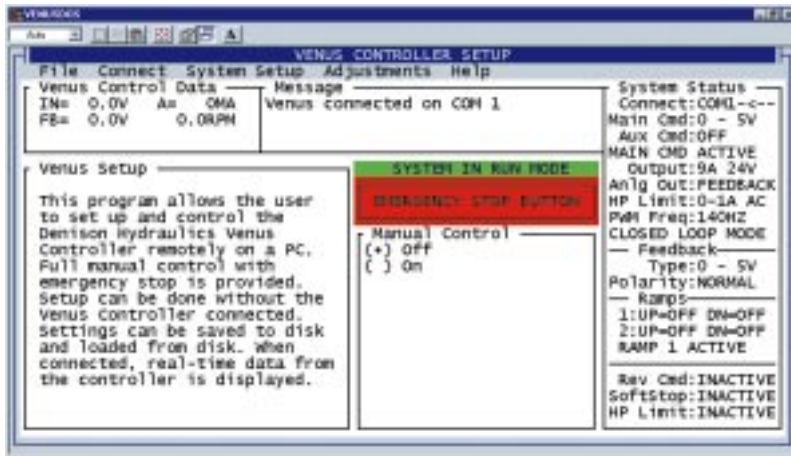

There are several benefits to using this method.

1. The control parameters can be entered and stored on disk, even when not connected to the Venus Controller.
2. Multiple setup files can be saved to disk.
3. The configuration can be retrieved from Venus for backup purposes.
4. The same setup file can be used for multiple Venus installations.

If running Microsoft Windows 95

- 486 or Pentium - based computer (with minimum 16M RAM).
- VGA or SuperVGA

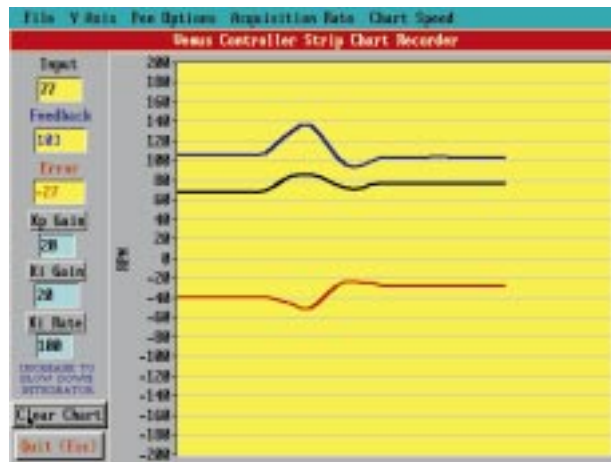

With the VGRAPH program, the input command, feedback signal and error can be displayed on the computer screen similar to that of a strip chart recorder. As the system performance is being displayed in real time, the tuning variables of Proportional Gain (Kp), Integrating Gain (Ki) and Integrating Rate (KIT) can be dynamically adjusted to get the optimum system performance.

**Configuration Data Storage**

All configuration data is stored in a non-volatile memory card inside Venus. If the controller fails and needs to be replaced, the memory card can be removed from the defective unit and inserted into the replacement unit configuring the new one exactly as the old.

**POWER SUPPLY REQUIREMENTS**

The Venus controller requires 12-24VDC to operate, the current requirements are determined by the type of actuator that is connected to Venus. The following list shows the current requirements of the DENISON Hydraulics actuators.

9A	Pump stroker 12V	12VDC at 1.5 AMPS Minimum
9A	Pump stroker 24V	24VDC at 1.0 AMPS Minimum
F5C	Flow control valve	24VDC at 1.5 AMPS Minimum
VP01	Pressure control valve	24VDC at 1.5 AMPS Minimum
4RP01	Pressure control valve 12V	12VDC at 1.5 AMPS Minimum
4RP01	Pressure control valve 24V	24VDC at 1.0 AMPS Minimum
3DP03	Open loop 24V	24VDC at 2.0 AMPS Minimum
3DP06	Open loop 12V	12VDC at 3.0 AMPS Minimum
3DP06	Open loop 24V	24VDC at 2.0 AMPS Minimum
4DP01	Open loop 12V	12VDC at 3.0 AMPS Minimum
4DP01	Open loop 24V	24VDC at 2.0 AMPS Minimum
4DP02	Open loop 12V	12VDC at 3.0 AMPS Minimum

**NOTICE:** 12V coils MUST be powered by a 12V power supply. Using a 24 Volts for 12V coils may result in an over current shut down which may cause the power supply output to brown out and reset Venus.

**Inputs**

Input commands can be voltages, current loops or potentiometers. Multiple inputs are permitted and are selected by the Main / Auxiliary input. The input command can also be programmed internally as a **LOCAL COMMAND** set digitally using the S20-14125 hand held terminal or with a PC computer using the S20-14131 program..

Feedback devices can be incremental optical encodes, passive and active magnetic pickups, DC tachometers, DC voltages or current loops, hydraulic flow meters, potentiometers, pressure, load and torque transducers, and current transformers for horse power limiting.

**Digital Inputs**

(12-24VDC Isolated Inputs with isolated GND on terminal 32)

Emergency stop

Voltage must be applied to this input to enable the controller's output.

Main input / Auxiliary input select

Connecting a voltage to terminal 28 will cause the controller to accept the input command from the Auxiliary input instead of the Main input.

Ramp 1 / Ramp 2 select

Ramp 1 is the default selection, applying a voltage to terminal 29 will select Ramp 2.

Soft stop

This option is used to set the output to zero at the rate set by the Soft Stop Time. This option can be enabled or disabled through the system configuration. When enabled, terminal 30 must be energized to allow the system outputs to function. De-energizing terminal 30 will engage the soft stop function. When disabled, terminal 30 may be left unconnected.

Reverse Command

Connecting a voltage will cause the controller to reverse the input command, i.e. with +5VDC input command and coil A output energized the new input will become -5VDC when reverse command is asserted and energize coil B output .

**Horse Power (HP) Limiting**

Venus can sense Horse Power in 1 of 2 ways.

- 1) Measure the electric motor current.
  - 2) Anti-stall - measure the prime mover's output shaft speed, i.e. diesel engine.
- 1) Electric Motor horsepower and electric motor current are directly related. HP is measured using a current transformer which is rated as a ratio of input current to output signal, i.e. 125:1, 125:20mA or 125:10VDC meaning that for an input current of 125 AmpsAC the transformer output will be 1 AmpAC, 20mADC or 10VDC. The output of the current transformer is fed into the Venus controller and compared to the adjustable limit. When the measured HP exceeds the pre-set limit the controller will de-stroke the pump as a function of the HP Limit gain.
  - 2) The prime mover's shaft speed, typically a diesel engine, is measured as a frequency and compared with the adjustable limit, as the HP requirements increase the prime movers RPM decreases. When the shaft speed drops below the limit, Venus will de-stroke the pump as a function of the HP Limit gain. Venus has only 1 frequency input, the user must decide which function it will serve, the system feedback or the HP limit.

**Ramp Generators**

Venus has two independently adjustable ramps. Ramp 1, when selected (default ramp), has adjustable up and down ramp times of 0.1 to 90 seconds. Ramp 1 up and ramp 1 down can be enabled or disabled independently, also Ramp 2, when selected (12 to 24VDC applied to terminal 29) has its own up and down ramp time adjustments of 0.1 to 90 seconds and ramp 2 up and ramp 2 down can be independently enabled or disabled.

NOTE: Using the S20-14131 PC interface program the Ramp 1 and Ramp 2 times are 0.1 to 300 seconds.

Each ramp can be configured in one of two different types of ramp models as shown below.

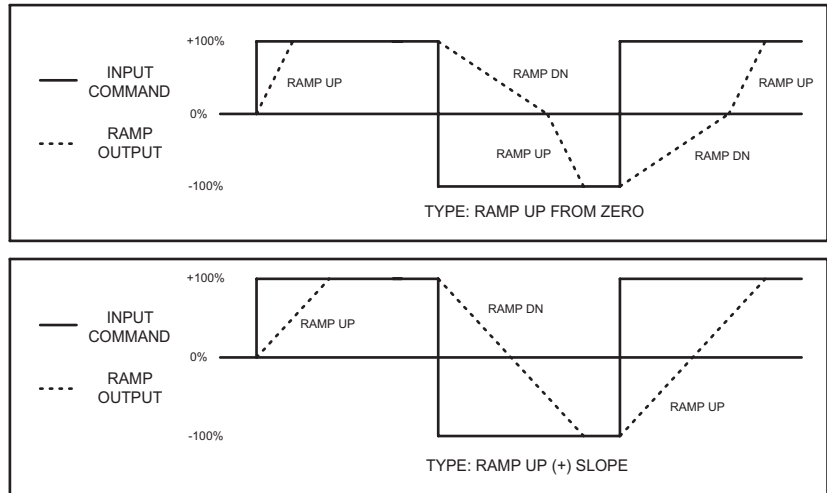

**Outputs**

The Venus controller has three outputs, one high current (coil A & coil B), one low voltage and one low current.

**High Level Outputs**

The high current output stage is a two channel PWM driver with current feedback for precise control of the current through the coil regardless of changes in coil resistance. Both channels are protected against short circuits across the coil and to ground.

The following is a list of DENISON's hydraulic actuators that Venus can control directly. Choosing one of the following selections using the S20-14125 terminal or the S20-14131 PC software will automatically configure the controller for the maximum current and PWM frequency required by the device.

9A	Pump stroker 12V or 24V
F5C	Flow control valve
VP01	Pressure control valve
4RP01	Pressure control valve
3DP03	Proportional directional valve (open loop) 12V or 24V
3DP06	Proportional directional valve (open loop) 12V or 24V
4DP01	Proportional directional valve (open loop) 12V or 24V
4DP02	Proportional directional valve (open loop) 12V or 24V

If the actuator you are using is not in the above list, the output stage can be configured per the following lists below.

Maximum Output Current

0.5Amps DC
1.0Amps DC
1.5Amps DC
3.0Amps DC

PWM Frequency

100Hz
120Hz
200Hz
2000Hz

**Absolute Minimum coil resistance**

Coils with ohmic values below the following list will cause an over current shut down of the high current output driver.  
 4.4 Ohms minimum for a 24VDC Supply.  
 2.2 Ohms minimum for a 12VDC Supply.

**Note:**The over current shut down threshold is 6 Amps. If the power supply is rated below this value and a short circuit condition exists the power supply may brown out, meaning that the output voltage from the power supply may drop below the minimum voltage required to power Venus. This will cause Venus to reset.

**Low Level Outputs**

The low voltage output is a  $\pm 5$ VDC analog output that can be configured in one of the following three modes.

Mode 1: Feedback echo -  $\pm 5$ VDC for -100% to +100% feedback signal as measured by the feedback device.

Mode 2: Input command echo -  $\pm 5$ VDC for -100% to +100% input command.

Mode 3: Controller output -  $\pm 5$ VDC for -100% to +100% controller output to other high current drivers.

**Note:** Mode 3 disables the high current PWM outputs.

The low current output is a 0-20mA or 4-20mA (user configurable) output representation of the 0-5VDC signal from the analog output. This is a unipolar output.

**I MINIMUM**

(+I MINIMUM & -I MINIMUM)

The output stage is designed to provide a step in output current that will move the pump stroker or valve through it's dead band when the input command exceeds 2.5%. Each output channel has it's own I minimum adjustment. When put in the I minimum setup mode, the controller ignores the input command and presets the internal command to exceed the 2.5% threshold and sets the I maximum (gain) to zero. This configuration will allow the adjustment of I minimum without the influence of any I maximum (gain).

For proper closed loop operation the controller must be calibrated to the feedback signal. This is done by first adjusting the (+)I minimum setting which may cause the feedback signal to be non-zero. The controller must be commanded to read the feedback offset, this will result in a displayed feedback of zero as the feedback offset is subtracted from the actual feedback signal being read.

**I MAXIMUM**

(+I MAXIMUM & -I MAXIMUM)

The I maximum adjustment allows the controller to set the output current to the stroker or valve that will yield maximum hydraulic output required by the overall system.

Again for proper closed loop operation the controller must be calibrated to the feedback signal at full system output. After setting the (+)I minimum, set the command input to 100% or its highest value and adjust (+)I maximum for maximum system output. The controller must be commanded to read the feedback signal which will equate the input command to the feedback signal to produce zero error.

**Status Codes**

The following is a list of status codes that Venus will display on the front panel RED LED marked STATUS.

1 <sup>st</sup> Blink	2 <sup>nd</sup> Blink	Status Code Definitions
1	1	Emergency Stop Active
1	2	Soft Stop Active
1	3	Horse Power Limit Active
1	4	Coil A Short Circuit
1	5	Coil A Open Circuit
2	1	Coil B Short Circuit
2	2	Coil B Open Circuit
2	3	Loss of Closed Loop Control
2	4	Feedback Wrong Polarity
2	5	Auxiliary Command Active
3	1	Ramp 2 Active
3	2	Reverse Command Active

The status codes will clear automatically when the indicated condition is corrected or is no longer active.



±5VDC Input Command

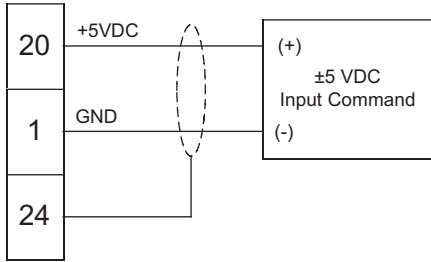

±0-20mA DC Input Command

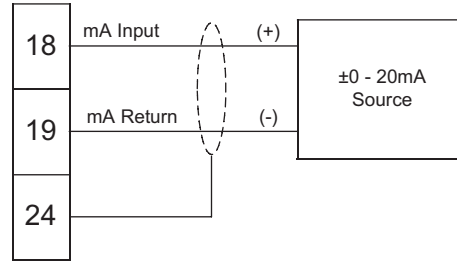

±10VDC Input Command

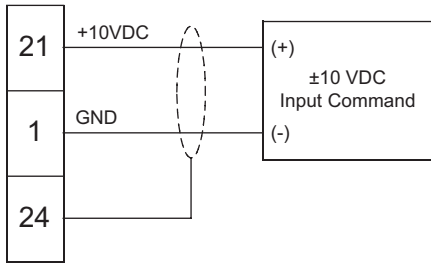

4-20mA DC Input Command

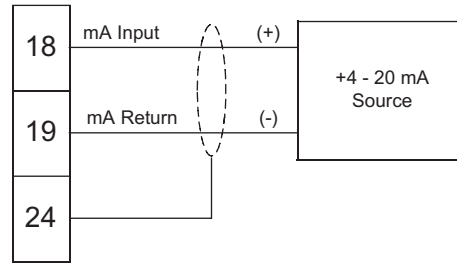

Potentiometer Input Command

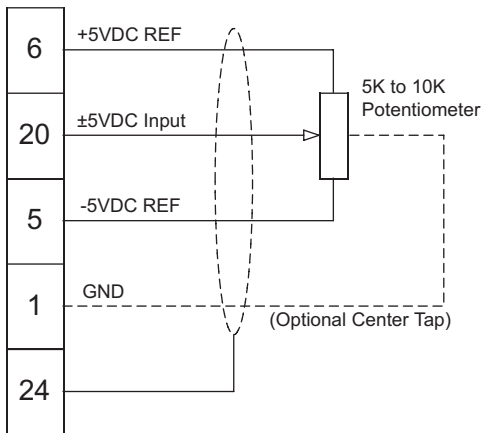

Local and Remote Input Commands

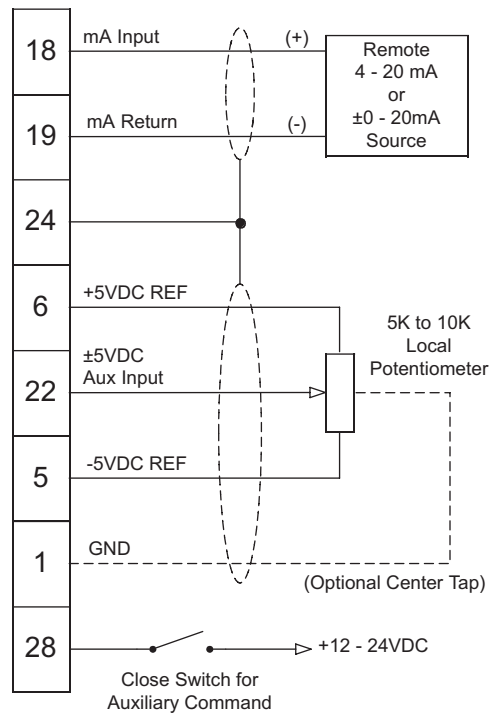

0-10VDC HP Limit Input

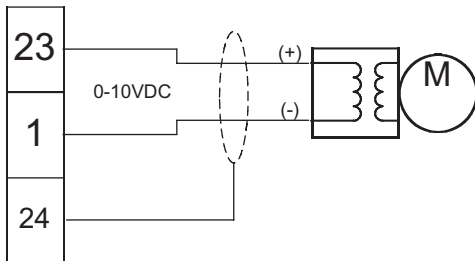

4-20mA DC HP Limit Input

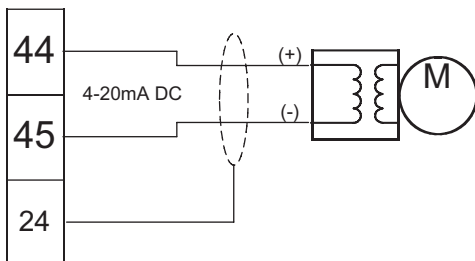

0-1Amp AC HP Limit Input

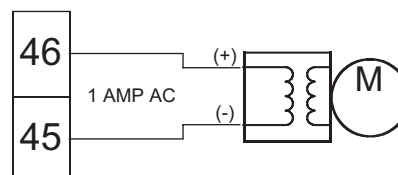

±5VDC Feedback

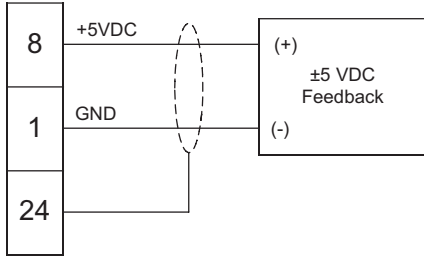

4-20mA DC Feedback

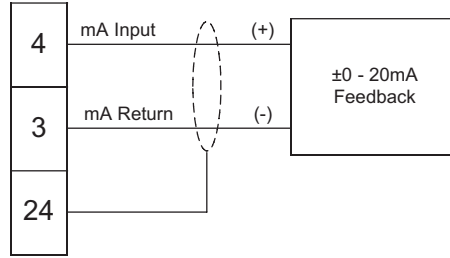

±10VDC Feedback

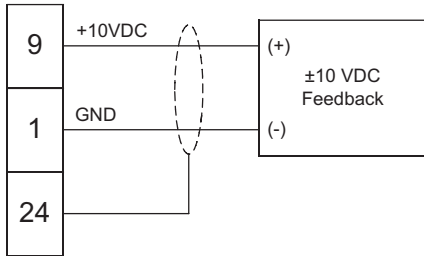

±0-20mA DC Feedback

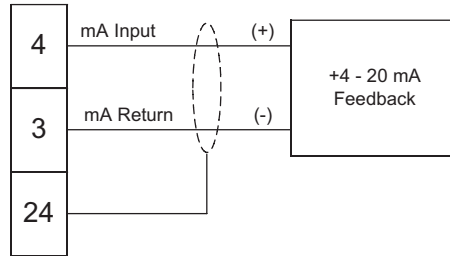

Differential Quadrature Encoder Feedback

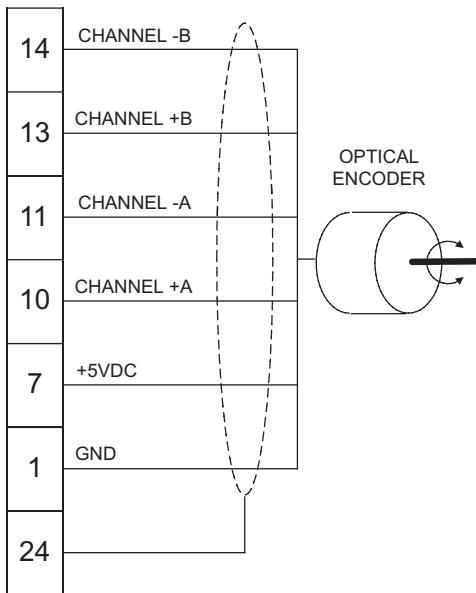

Quadrature Encoder Feedback

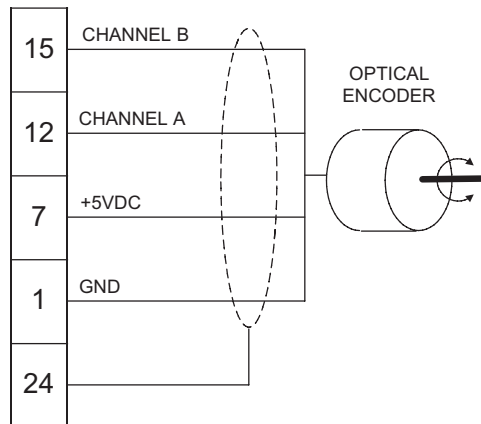

Magnetic Pickup Feedback

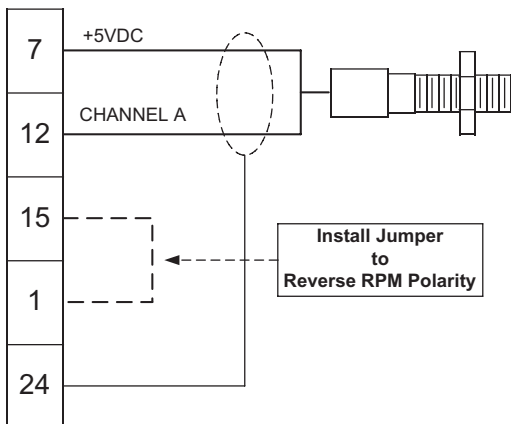

Proximity Probe Feedback

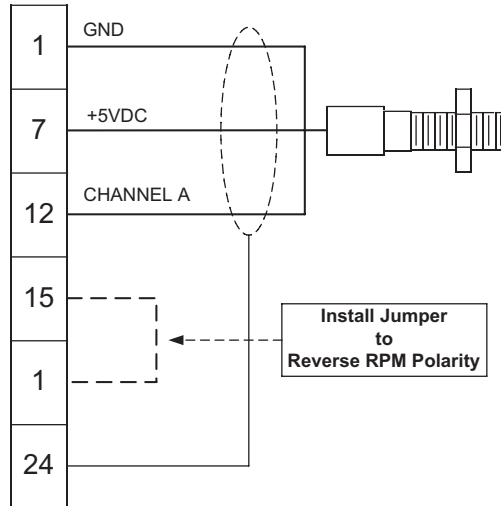

ANALOG OUTPUT WIRING DIAGRAMS

0-20mA OR 4-20mA  
OUTPUT

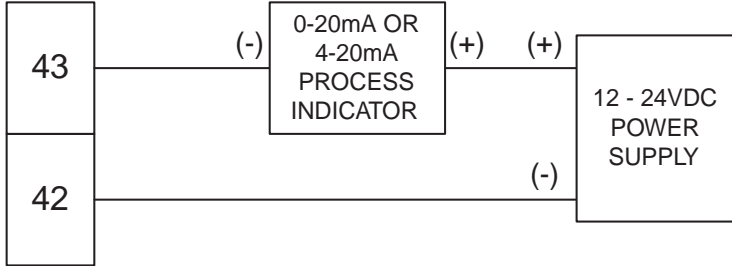

±5VDC ANALOG  
OUTPUT

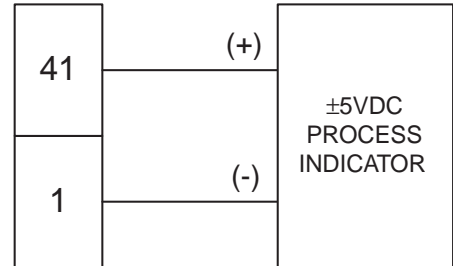

Terminal Block Definitions

TB #	Description
1	Signal ground
2	Signal ground
3	mA return feedback
4	mA input feedback
5	-5 VDC Reference voltage
6	+5 VDC Reference voltage
7	+5 VDC Encoder excitation
8	±5 VDC feedback
9	±10 VDC feedback
10	+ Differential Encoder input Channel A
11	- Differential Encoder input Channel A
12	Single ended encoder Channel A
13	+ Differential Encoder input Channel B
14	- Differential Encoder input Channel B
15	Single ended encoder Channel B
16	Magnetic pickup
17	Magnetic pickup
18	mA return command
19	mA input command
20	±5 VDC input command
21	±10 VDC input command
22	±5 VDC auxiliary command
23	0 - 10 VDC HP limit input

TB #	Description
24	Earth Ground
25	Power Ground
26	+ Power Supply
27	Emergency Stop
28	Main / Auxiliary
29	Ramp 1 / Ramp 2 input
30	Soft Stop Command input
31	Reverse Command input
32	Isolated ground
33	Signal ground
34	N / C
35	Coil B return
36	Coil B output
37	Coil A output
38	Coil A return
39	N / C
40	Signal ground
41	±0 - 5VDC output
42	4 - 20 mA return
43	4 - 20 mA output
44	4-20 mA DC HP limit input
45	HP limit signal return
46	1.0 Amp AC HP limit input

RS232 Connector Definitions

Pin #	Description
1	No Connect
2	TxD (RS232 Transmit)
3	RxD (RS232 Receive)
4	No Connect
5	Signal Ground
6	No Connect
7	No Connect
8	No Connect
9	+5VDC (Terminal Power)

PC Interface  
Wiring Diagrams

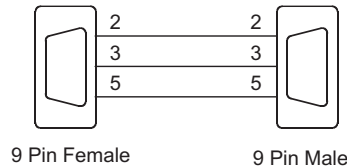

9 Pin Female

9 Pin Male

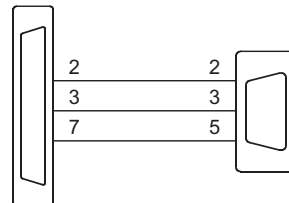

25 Pin Female

9 Pin Male

# BLOCK DIAGRAM

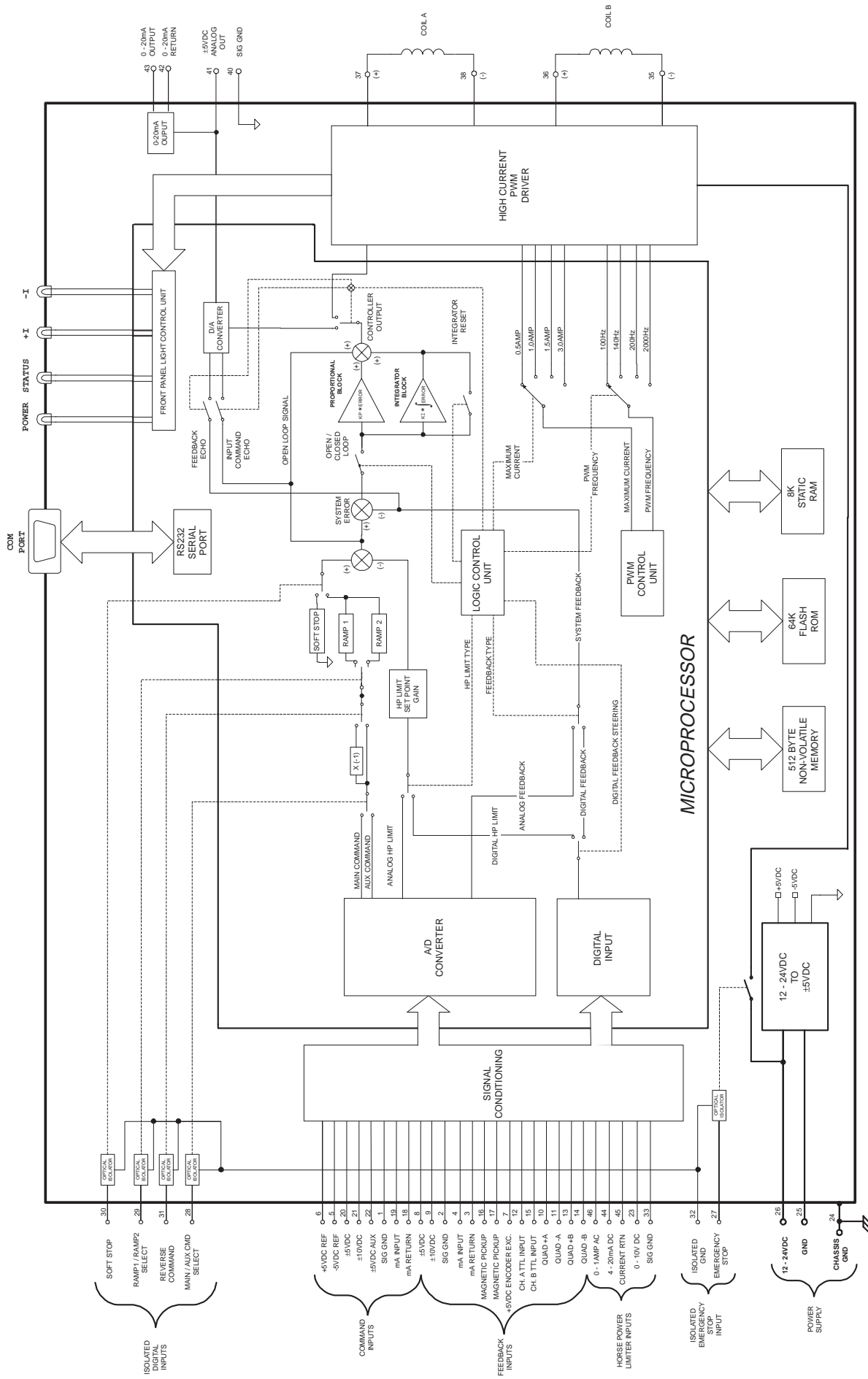

**CONTROLLER OPERATION**

The diagram below shows how the open loop and Proportional / Integral (PI) closed loop signal paths work together to form the complete closed loop control system.

The output of the Proportional block is the system error multiplied by  $K_P$ .  $K_P$  is the Proportional gain and is user adjustable.

The output of the Integrator block is the mathematical integration of system error multiplied by  $K_I$ .  $K_I$  is the Integrator gain and is user adjustable. The rate at which it integrates is controlled by the  $K_{IT}$  variable. Larger  $K_{IT}$  values produce a slower integrator and is user adjustable.

When in open loop mode the output of the proportional block is forced to zero and the integrator reset switch is activated forcing it to zero. The final output is the open loop signal which consists of the input command plus the  $I_{min}$  and  $I_{max}$  settings in the high current PWM driver.

Setting the controller in closed loop mode de-activates the integrator reset allowing it to integrate the system error and multiplying it by the  $K_I$  variable. This value is summed with the output of the proportional block and the open loop signal described above.

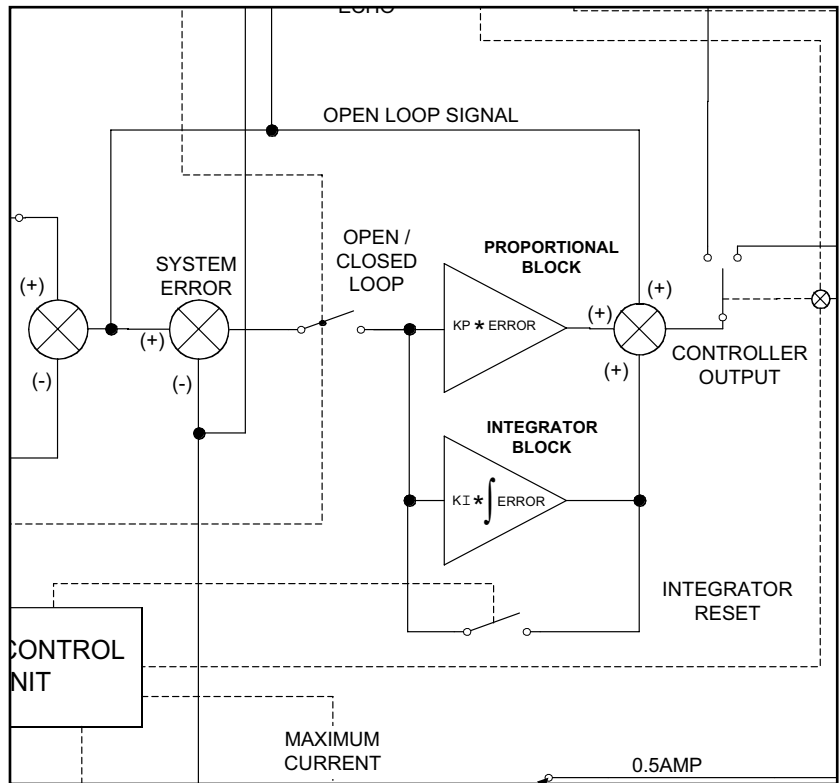

The CP variable (controller percentage) adjusts the amount of influence the PI section has over the system response. CP sets the control authority which limits the amount of error correction the PI section will contribute to the final controller output. The CP range is 1 to 100%.

Venus has a built in safety feature that will put the controller in open loop mode if the system error exceeds the ME variable (maximum error) for a time longer than the MET variable (maximum error timer).

ME is entered as a percent of maximum error with a range of 1% to 100%. MET has a range of 0 to 30 seconds. If the AR variable (automatic restart) is on, set to a value of 1, then Venus will put the controller back in closed loop mode after the ART (automatic restart timer) has passed.

AR has a range of 0 to 1 with 0 being off and 1 being on. ART has a range of 0 to 3600 seconds.

## STATUS CODE

## POSSIBLE SOLUTIONS

**11 - EMERGENCY STOP**

To dis-engage Emergency stop

1. Apply +12 to +24VDC to terminal #27.
2. Verify that terminal #33 is connected to the same ground that is used for terminal #27.

**12 - SOFT STOP**

To dis-engage Soft stop

1. If Soft stop is not used then disable through system configuration.
2. If Soft stop is used then apply +12 to +24VDC to terminal #30.
3. Verify that terminal #33 is connected to the same ground that is used for terminal #27.

If Soft stop is not engaging, check the Soft stop enable through system configuration.

**13 - HP LIMIT ACTIVE**

If HP limiting is not required at all, select HP limit type to be off in the system configuration.

If the HP limiter is active when it is not supposed to be then check that the correct sensor is selected in the system configuration, verify that the HP limit setpoint is correct.

**14 - COIL A SHORT CIRCUIT****21 - COIL B SHORT CIRCUIT**

1. Check the wiring for a short circuit condition on coil A or coil B.
2. Verify that the coil resistance is not too low.
3. Verify that the supply voltage is not too high for the coil resistance.

**15 - COIL A OPEN CIRCUIT****22 - COIL B OPEN CIRCUIT**

1. Verify that the wiring of the coils is correct.
2. Verify that the coil resistance is not too high.
3. Verify that the supply voltage is not too low for the coil resistance.

**23 - LOSS OF CLOSED LOOP CONTROL**

This condition means that for whatever reason Venus can not control the feedback signal within the set parameters.

1. Reset the  $\tau$  minimum and  $\tau$  maximum and re-calibrate the feedback.
2. Increase the CP (controller percentage) variable to allow the controller to have enough head room to control the feedback.
3. Increase the ME (maximum error) variable.
4. Increase the MET (maximum error timer) variable.

**24 - FEEDBACK WRONG POLARITY**

1. If feedback is a single channel digital signal then place a jumper from terminal #15 to terminal #2.
2. If the jumper is already installed then remove jumper.
3. If feedback is a dual channel digital signal then change channel A with channel B.
4. If feedback is an analog signal then reverse the 2 wires.

The Venus Controller requires configuration before the unit will function properly. System parameters must be programmed by the user to configure the controller to the application.

The hand held terminal, S20-14125, will prompt the user through a menu system to setup Venus. No other programming tools are required.

To begin type SETUP then press the ENTER key.



S20-14125 Hand Held Programming Terminal  
(Optional, Sold separately).

The Output Type, Input Command and the Feedback Type are the minimum settings that must be configured before the unit can run properly.

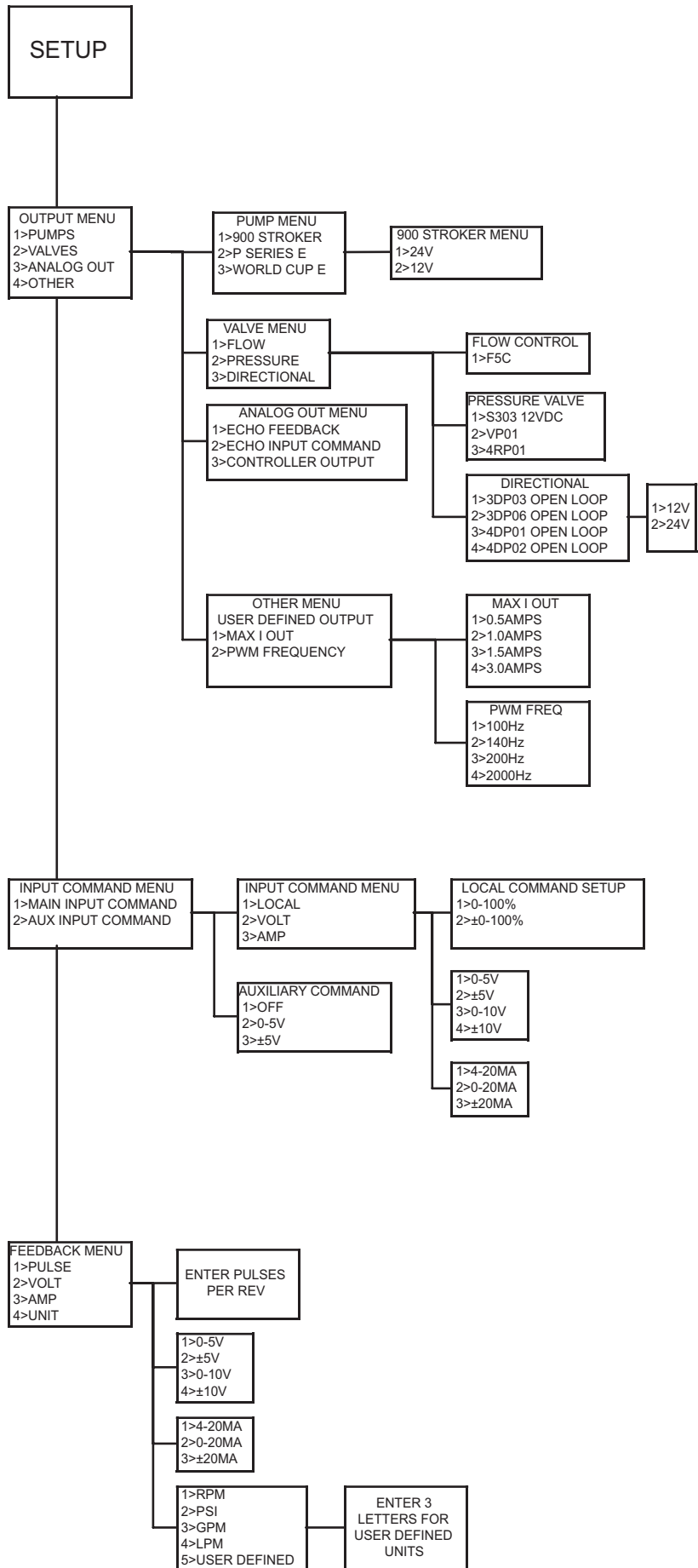

**INITIAL SETUP**

Press CTRL F5 together to setup the 020-14103 Venus controller.

Figure 2 on page 17 is the system setup diagram. Follow the menu prompts to configure the controller to the type of hydraulics device you are connecting to.

After the controller has been configured the following set-up procedure must be followed to ensure proper operation.

**+I MINIMUM (COIL A)**

Press Shift F1 together. Use table 1 to adjust the minimum output current such that the dead band of the hydraulic actuator is removed. After setting +I Minimum press CTRL F1 to calibrate the controller for zero feedback. Press Shift esc to exit.

**+I MAXIMUM (COIL A)**

Press Shift F2 together. Use table 2 to set the maximum hydraulic output that the system requires for +maximum command. After the system stabilizes press CTRL F2 to calibrate the feedback span. The system is now calibrated to your hydraulic system. Press Shift esc to exit.

If the system is bi-directional do the following.

**-I MINIMUM (COIL B)**

Press Shift F3 together. Use table 3 to adjust the minimum output current such that the dead band of the hydraulic actuator is removed. Press Shift esc to exit.

**-I MAXIMUM (COIL B)**

Press Shift F4 together. Use table 4 to set the maximum hydraulic output that the system requires for -maximum command. Press Shift esc to exit.

**HORSE POWER (HP) LIMITING**

Use Table 5 for HP Limiting setup definitions.

**RAMPS**

Use table 6 to set ramp 1 time.  
Use table 7 to set ramp 2 time.

**MANUAL CONTROL**

Use table 8 for Manual Control

**CLOSED LOOP CONTROLLER  
ADJUSTMENTS**

The controller must be tuned for stable, non-oscillating control. Table 9 shows the function key definitions. The controller must be adjusted or tuned to match the characteristics of the hydraulic system. Adjusting Ki (integrator variable) and Kp (proportional variable) will allow the user to fine tune Venus for accurate, stable control. The KIT variable controls the speed (rate of integration) of Ki, where Ki controls the integrator gain.



# S20-14125 Hand Held Terminal Menu Flow Chart

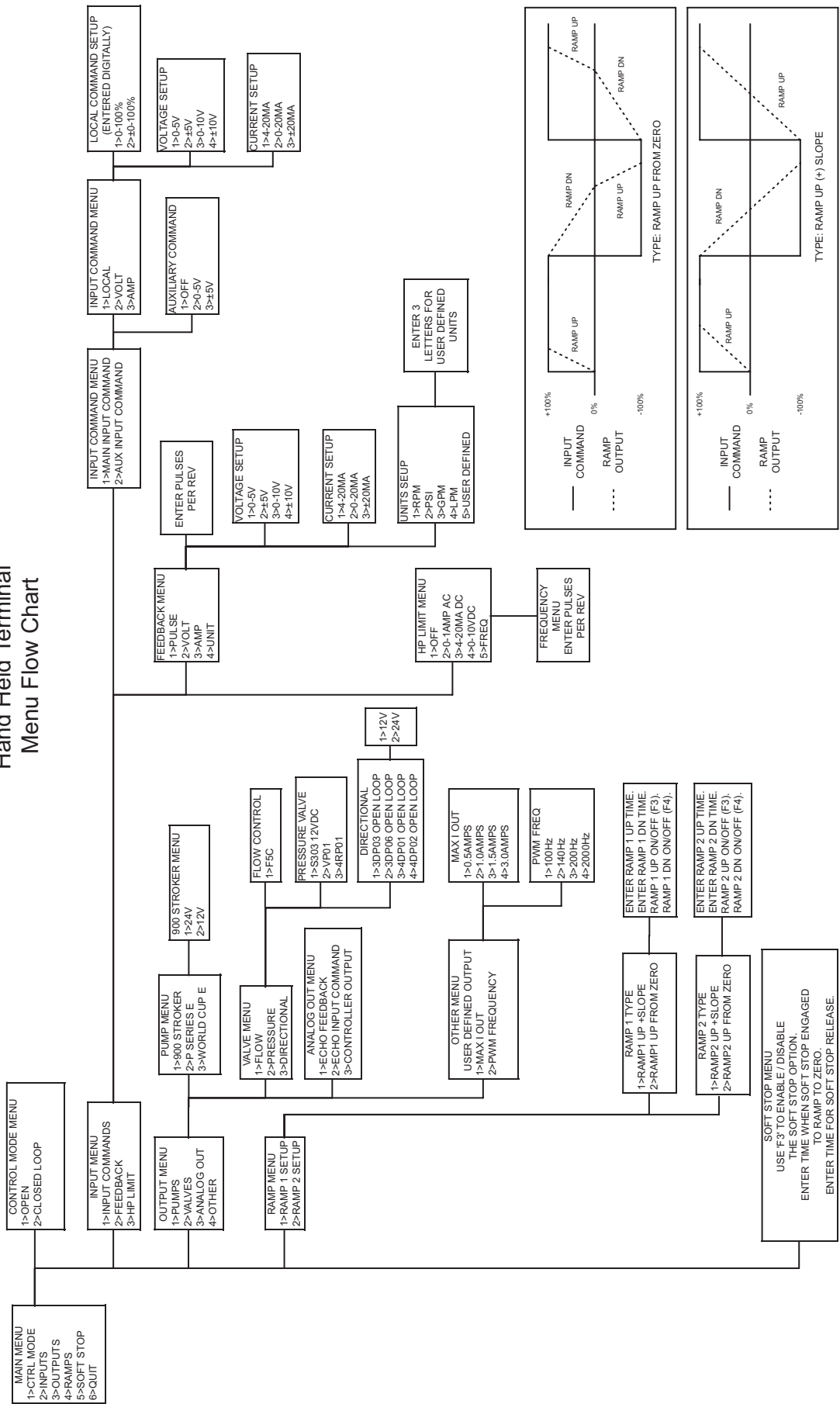

Fig. 2

DENISON>

At the Denison Prompt the following Function key definitions are in effect.

Function-Key	Definition	
F1	Diagnostic Display	
F2	Normal data display	
F3		
F4		
F5		
SHIFT F1	I MIN A	Table 1
SHIFT F2	I MAX A	Table 2
SHIFT F3	I MIN B	Table 3
SHIFT F4	I MAX B	Table 4
SHIFT F5	HP Limit	Table 5
SHIFT E	EMERGENCY STOP	
CTRL F1	Ramp 1	Table 6
CTRL F2	Ramp 2	Table 7
CTRL F3	Set Manual Control Mode On	Table 8
CTRL F4	Control Parameters	Table 9
CTRL F5	System Setup	

TABLE 1

SHIFT F1 I MIN A Menu

Function-Key	Definition
F1	Increase I MIN A (Course adjustment)
F2	Increase I MIN A (Fine adjustment)
F3	Decrease I MIN A (Course adjustment)
F4	Decrease I MIN A (fine adjustment)
F5	
SHIFT F1	
SHIFT F2	
SHIFT F3	
SHIFT F4	
SHIFT F5	
SHIFT E	EMERGENCY STOP
CTRL F1	Set feedback zero (0)
CTRL F2	
CTRL F3	
CTRL F4	
CTRL F5	
ESC	EXIT

TABLE 2

SHIFT F2 I MAX A Menu

Function-Key	Definition
F1	Increase I MAX A (Course adjustment)
F2	Increase I MAX A (Fine adjustment)
F3	Decrease I MAX A (Course adjustment)
F4	Decrease I MAX A (fine adjustment)
F5	Set manual command to zero (0)
SHIFT F1	Increase manual command (Course adjustment)
SHIFT F2	Increase manual command (Fine adjustment)
SHIFT F3	Decrease manual command (Course adjustment)
SHIFT F4	Decrease manual command (Fine adjustment)
SHIFT F5	Set manual command to (+) 100%
SHIFT E	EMERGENCY STOP
CTRL F1	
CTRL F2	Set feedback to full scale
CTRL F3	Set manual control mode on
CTRL F4	Set manual control mode off
CTRL F5	Set manual command to (-) 100%
ESC	EXIT

TABLE 3

SHIFT F3 I MIN B Menu	
Function	Definition
F1	Increase I MIN B (Course adjustment)
F2	Increase I MIN B (Fine adjustment)
F3	Decrease I MIN B (Course adjustment)
F4	Decrease I MIN B (fine adjustment)
F5	
SHIFT F1	
SHIFT F2	
SHIFT F3	
SHIFT F4	
SHIFT F5	
SHIFT E	EMERGENCY STOP
CTRL F1	
CTRL F2	
CTRL F3	
CTRL F4	
CTRL F5	
ESC	EXIT

TABLE 4

SHIFT F4 I MAX B Menu	
Function-Key	Definition
F1	Increase I MAX B (Course adjustment)
F2	Increase I MAX B (Fine adjustment)
F3	Decrease I MAX B (Course adjustment)
F4	Decrease I MAX B (fine adjustment)
F5	Set manual command to zero (0)
SHIFT F1	Increase manual command (Course adjustment)
SHIFT F2	Increase manual command (Fine adjustment)
SHIFT F3	Decrease manual command (Course adjustment)
SHIFT F4	Decrease manual command (Fine adjustment)
SHIFT F5	Set manual command to (+) 100%
SHIFT E	EMERGENCY STOP
CTRL F1	
CTRL F2	
CTRL F3	Set manual control mode on
CTRL F4	Set manual control mode off
CTRL F5	Set manual command to (-) 100%
ESC	EXIT

TABLE 5

SHIFT F5 HP LIMIT Menu	
Function-Key	Definition
F1	Increase gain (Course adjustment)
F2	Increase gain (Fine adjustment)
F3	Set HP LIMIT trip point
F4	
F5	Set manual command to zero (0)
SHIFT F1	Increase manual command (Course adjustment)
SHIFT F2	Increase manual command (Fine adjustment)
SHIFT F3	Decrease manual command (Course adjustment)
SHIFT F4	Decrease manual command (Fine adjustment)
SHIFT F5	Set manual command to (+) 100%
SHIFT E	EMERGENCY STOP
CTRL F1	Decrease gain (Course adjustment)
CTRL F2	Decrease gain (Fine adjustment)
CTRL F3	Begin manual control
CTRL F4	End manual control
CTRL F5	Set manual command to (-) 100%
ESC	EXIT

TABLE 6

CTRL F1 Ramp 1 Menu	
Function-Key	Definition
F1	Enter ramp up time
F2	Enter ramp down time
F3	Ramp up on / off
F4	Ramp down on / off
F5	Set manual command to zero (0)
SHIFT F1	Increase manual command (Course adjustment)
SHIFT F2	Increase manual command (Fine adjustment)
SHIFT F3	Decrease manual command (Course adjustment)
SHIFT F4	Decrease manual command (Fine adjustment)
SHIFT F5	Set manual command to (+) 100%
SHIFT E	EMERGENCY STOP
CTRL F1	
CTRL F2	
CTRL F3	Set manual control mode on
CTRL F4	Set manual control mode off
CTRL F5	Set manual command to (-) 100%
ESC	EXIT

TABLE 7

CTRL F2 Ramp 2 Menu	
Function-Key	Definition
F1	Enter ramp up time
F2	Enter ramp down time
F3	Ramp up on / off
F4	Ramp down on / off
F5	Set manual command to zero (0)
SHIFT F1	Increase manual command (Course adjustment)
SHIFT F2	Increase manual command (Fine adjustment)
SHIFT F3	Decrease manual command (Course adjustment)
SHIFT F4	Decrease manual command (Fine adjustment)
SHIFT F5	Set manual command to (+) 100%
SHIFT E	EMERGENCY STOP
CTRL F1	
CTRL F2	
CTRL F3	Set manual control mode on
CTRL F4	Set manual control mode off
CTRL F5	Set manual command to (-) 100%
ESC	EXIT

TABLE 8

CTRL F3 Manual Control Menu	
Function-Key	Definition
F1	
F2	
F3	
F4	
F5	Set manual command to zero (0)
SHIFT F1	Increase manual command (Course adjustment)
SHIFT F2	Increase manual command (Fine adjustment)
SHIFT F3	Decrease manual command (Course adjustment)
SHIFT F4	Decrease manual command (Fine adjustment)
SHIFT F5	Set manual command to (+) 100%
SHIFT E	EMERGENCY STOP
CTRL F1	
CTRL F2	
CTRL F3	
CTRL F4	
CTRL F5	Set manual command to (-) 100%
ESC	EXIT

TABLE 9

CTRL F4 Control Parameters Menu	
Function-Key	Definition
F1	Enter Ki data (Integrator gain)
F2	Enter Kp data (Proportional gain)
F3	Enter KiT data (Integrator time constant, rate of integration)
F4	
F5	Set manual command to zero (0)
SHIFT F1	Increase manual command (Course adjustment)
SHIFT F2	Increase manual command (Fine adjustment)
SHIFT F3	Decrease manual command (Course adjustment)
SHIFT F4	Decrease manual command (Fine adjustment)
SHIFT F5	Set manual command to (+) 100%
SHIFT E	EMERGENCY STOP
CTRL F1	
CTRL F2	
CTRL F3	Set manual control mode on
CTRL F4	Set manual control mode off
CTRL F5	Set manual command to (-) 100%
ESC	EXIT

**SUPPLIMENTAL COMMANDS**

The following are commands that the menu structure does not support. These are system level commands that allow low lever configuration. Entering the variables only will display their current value, entering the variable with an equal sign will change the value. i.e. AZ=10.

<b>AZ</b>	Analog output zero. This is the analog output offset adjustment value. This command will return the numeric value of the current level of offset with zero being no offset.
<b>AZ=n</b>	Sets an offset value where <b>n</b> is a positive integer with a range of 0 to 50.
<b>CP</b>	The CP variable (controller percentage) adjusts the amount of influence the P I section has over the system response. CP sets the control authority which limits the amount of error correction the P I section will contribute to the final controller output.
<b>CP=n</b>	Sets the control authority value where <b>n</b> is a positive integer with a range of 0 to 100.
<b>MA</b>	Milliamp output type. This determines whether the low level current output is 0-20mA or 4-20mA. This command will return the current output type.
<b>MA=n</b>	Sets the Milliamp output type where <b>n</b> is 0 = 0-20mA, and 4 = 4-20mA.
<b>ME, MET &amp; MED</b>	Venus has a built in safety feature that will put the controller in open loop mode if the system error exceeds the ME variable (maximum error) for a time longer then the MET variable (maximum error timer). MED is the maximum error detection enable variable.
<b>ME=n</b>	ME is entered as a percent of maximum error with a range of 1% to 100% where <b>n=1</b> to 100.
<b>MET=n</b>	MET has a range of 0 to 30 seconds, <b>n=0</b> to 30.
<b>MED=n</b>	MED has a range of 0 to 1 with 0 being off and 1 being on.
<b>AR</b>	If the AR variable (automatic restart) is on, set to a value of 1, then Venus will put the controller back in closed loop mode after the ART (automatic restart timer) time has passed.
<b>AR=n</b>	AR has a range of 0 to 1 with 0 being off and 1 being on.
<b>ART=n</b>	ART has a range of 0 to 3600 seconds.
<b>CFE</b>	If the CFE variable (current fault enable) is on, set to a value of 1, then Venus will monitor the high current outputs for open / short circuit conditions. If an output is short circuited then Venus will turn off that output, flash the Status light and wait for approximately 10 seconds and try the output again. If the output is open circuited then Venus will flash the Status light only no other action will be taken.
<b>CFE=n</b>	CFE has a range of 0 to 1 with 0 being off and 1 being on.



**International Distributors**

**In Europe:**

Cyprus  
Eastern Europe  
The Faroe Islands  
Finland  
Greece  
Iceland  
Norway  
Portugal  
Switzerland  
Turkey

**In Africa:**

Algeria  
Egypt  
Ivory Coast  
Morocco  
Nigeria  
South Africa  
Togo  
Tunisia

**In Middle East:**

Iran  
Israel  
Lebanon  
Pakistan  
Qatar  
Saudi Arabia  
Syria  
United Arab Emirates

**In Far East:**

Indonesia  
Korea  
Malaysia  
New Zealand  
Philippines  
Thailand

**Australia**

DENISON HYDRAULICS Pty. Ltd.  
41-43 St. Hillers Road  
P.O. Box 192  
Auburn, N.S.W. 2144  
Australia  
Tel. (612) 9646 5200  
Fax (612) 9643 1305

**Other sales offices:**

Queensland  
South Wantirna Victoria  
Western Australia

**Austria**

DENISON HYDRAULIK GmbH  
Zweigniederlassung Linz  
Haidbachstraße 69  
A-4061 Pasching  
Austria  
Tel. (43) 7229 4887  
Fax (43) 7229 63092

**Benelux**

DENISON HYDRAULICS  
BENELUX B. V.  
Pascalstraat 100  
3316 Dordrecht  
Holland  
Tel. (31) 786179 900  
Fax (31) 786175 755

**Canada**

DENISON HYDRAULICS  
CANADA Inc.  
2320 Bristol Circle, Unit 1  
Oakville, ON L6H 5S2  
Canada  
Tel. (905) 829 5800  
Fax (905) 829 5805

**Other sales offices:**

Montreal, QC  
Calgary, AB

**Denmark**

DENISON HYDRAULIK  
DENMARK A/S  
Industrikrogen 2  
DK-2635 Ishøj  
Denmark  
Tel. (45) 4371 15 00  
Fax (45) 4371 15 16

**Finland**

DENISON HYDRAULICS  
P.O. Box 36  
FIN-08101 Lohja  
Finland  
Tel. (358) 208 33 045  
Fax (358) 207 33 045

**France**

DENISON HYDRAULICS  
FRANCE SA  
14, route du Bois Blanc  
BP 539  
18105 Vierzon  
France  
Tel. (33) 2 48 53 01 20  
Fax (33) 2 48 75 02 91

**Other sales offices:**

Bordeaux  
Lyon  
Paris

**Germany**

DENISON HYDRAULIK GmbH  
Herderstrasse 26  
D-40721 Hilden  
Germany  
Tel. (49) 2103 940-6  
Fax (49) 2103 940-880

**Other sales offices:**

Dresden  
Hanover  
Stuttgart

**Great Britain**

DENISON HYDRAULICS U.K.  
Ltd.  
Kenmore Road  
Wakefield 41, Industrial Estate  
Wakefield, WF20XE  
West Yorkshire  
England  
Tel. (44) 19 24 826 021  
Fax (44) 19 24 826 146

**Other sales offices:**

Burgess Hill

**Hong Kong**

DENISON HYDRAULICS Ltd.  
Unit 3, 25/F Wharf Cable Tower  
9 Hoi Shing Road  
Tsuen Wan  
N.T., Hong Kong  
Tel. (852) 24988381  
Fax (852) 24991522

**Italy**

DENISON HYDRAULICS S.r.l.  
Viale Europa 68  
20090 Cusago  
Milano  
Italy  
Tel. (39) 2 90330 1  
Fax (39) 2 90390 695

**Japan**

DENISON JAPAN Inc.  
4-2-1 Tsujido-Shinmachi  
Fujisawa 251,  
Japan  
Tel. (81) 466 35 3257  
Fax (81) 466 35 2029

**Other sales office:**

Osaka

**Mexico, Central America, South America and Caribbean**

**Countries Contact**  
DENISON HYDRAULICS Inc.  
6167 NW 181 Terrace Circle North  
Miami, FL 33015  
USA  
Tel. (305) 362 2246  
Fax (305) 362 6220

**P.R. China**

DENISON HYDRAULICS Ltd.  
3F, No. 1, Mao Jia Zhai, Bai Lian Jing  
Pudong New Area,  
Shanghai 200126, China  
Tel. (86) 21 5886 8991  
Fax (86) 21 5886 1978

**Singapore**

DENISON HYDRAULICS S.E.A. Pte.  
Ltd.  
No. 11 Lorong Tukang Dua  
Singapore 2261  
Tel. (65) 2687840  
Fax (65) 2687847

**Spain**

DENISON HYDRAULICS, S.A.  
Gomis, 1  
08023 Barcelona  
Spain  
Tel. (34) 3418 46 87  
Fax (34) 3211 65 07

**Other sales offices:**

San Sebastian

**Sweden**

DENISON HYDRAULICS  
SVENSKA AB  
Sporregatan 13  
213 77 - Malmö  
Sweden  
Tel. (46) 40 21 04 40  
Fax (46) 40 21 47 26

**Other sales offices:**

Spånga

**Taiwan**

DENISON HYDRAULICS Ltd.  
6F-10, No. 79, Sec. 2, Roosevelt road,  
Taipei, Taiwan, R.O.C.  
Tel. (886) 2 3645101 / 3645102  
Fax (886) 2 3639025

**USA**

DENISON HYDRAULICS Inc.  
14249 Industrial Parkway  
Marysville, OH 43040  
USA  
Tel. 937 644 3915  
Fax 937 642 3738  
For nearest Distributor:  
Call toll free 1 800 551 5956  
E-Mail address:  
denison@denisonhydraulics.com  
WWW address:  
http://www.denisonhydraulics.com

**Other sales offices:**

Fulton, CA  
Mulberry, FL  
Moline, IL  
Rock Island, IL  
Kentwood, MI  
Portland, OR  
Memphis, TN  
Arlington, TX  
Houston, TX

**Other European, Middle East and African Countries Contact**

DENISON HYDRAULICS  
FRANCE SA  
14, route du Bois Blanc  
BP 539  
18105 Vierzon Cedex  
France  
Tel. (33) 2 48 53 01 44  
Fax (33) 2 48 53 01 46

Your local DENISON representative