

DENISON HYDRAULICS Jupiter 900 Driver Card Panel Mount Version

Series S20-14087-0 Design C

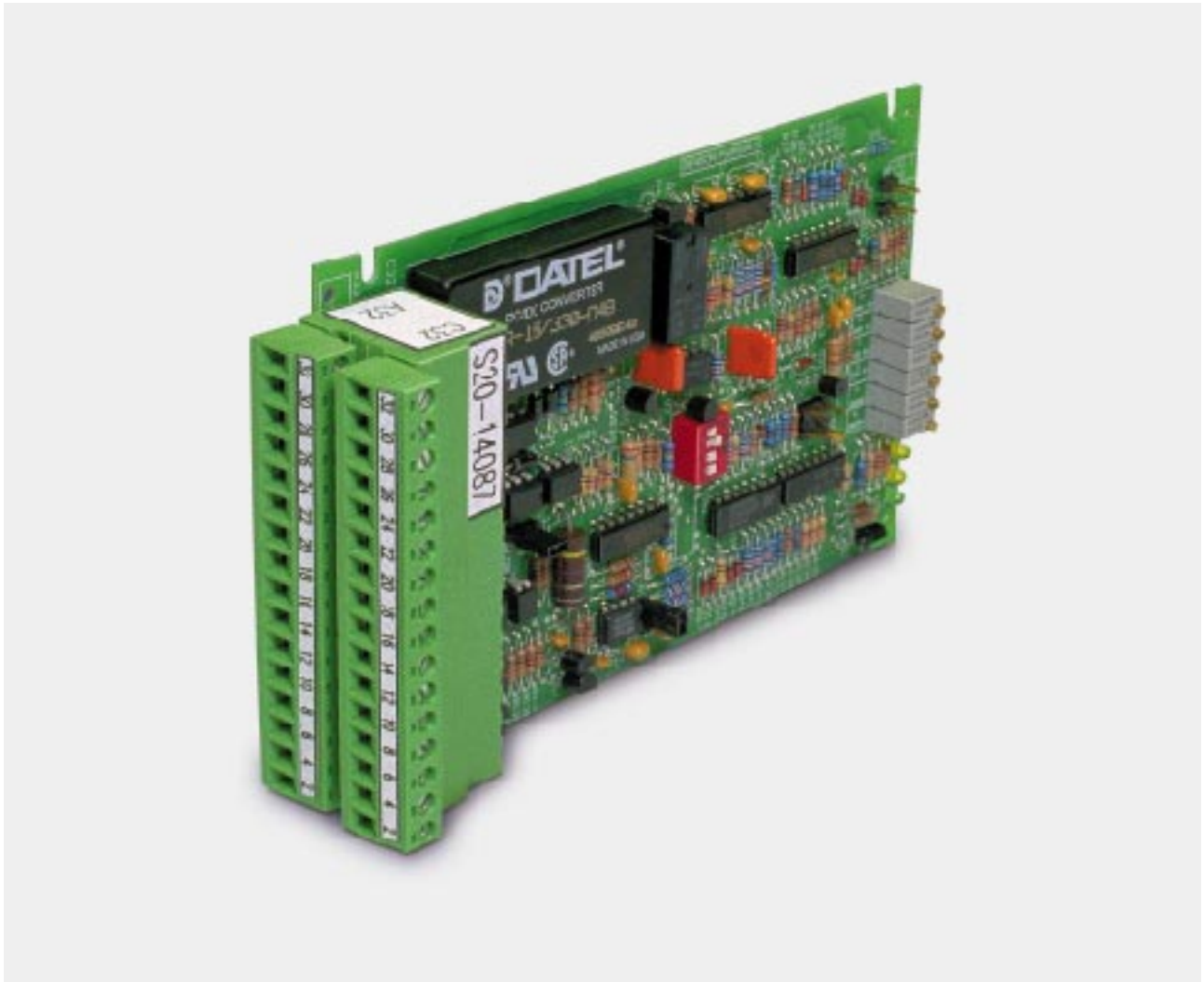

Publ. 9-AM683-A *replaces 9-AM683*

DENISON Hydraulics

MANUFACTURER'S NAME DENISON HYDRAULICS

MANUFACTURER'S ADDRESS 14249 Industrial Parkway
Marysville, Ohio 43040-9504, USA

declares that the product

PRODUCT NAME Jupiter 900 Driver Card (Panel Mount Version)

PRODUCT PART NUMBER S20-14087-0

conforms to the following product specifications

EMC: EN50081-2: March 1994 generic emissions for heavy industry¹
EN55011: 7/1992 radiated or conducted EMI – 30-1000MHz

EN50082-2: 1995 generic immunity for heavy industry¹
ENV50140: 8/1993 – 10V/m, 80-1000MHz – Performance Criteria B

EN61000-4-2, IEC801-2 electrostatic discharge (ESD)
8KV air discharge – Performance Criteria A
4KV contact discharge – Performance Criteria A

EN61000-4-4: 5/1995 fast transient rejection
2KV power supply wires – Performance Criteria B

SUPPLEMENTARY INFORMATION

This product is the panel-mounted version of the Jupiter 900 Driver, S20-14078, which was tested in an EMC TEST Laboratory in Germany. The S20-14087 uses the same electronic assembly as the S20-14078 less the Euro-style front panel assembly. Hence by construction, this unit complies with the EMC Directive 89/336 and the CE Marking requirements.

¹The product group was tested in a typical system configuration with DENISON HYDRAULICS Jupiter Series products or recommended second source products. The tested product was mounted in a NEMA 4 enclosure (or equivalent) and all cables exiting the enclosure were shielded (screened). Enclosure and cable shields were connected to earth ground (PE).

USA CONTACT

Office of Director of Quality
DENISON HYDRAULICS
14249 Industrial Parkway
Marysville, Ohio 43040

EUROPEAN CONTACT

DENISON HYDRAULICS Sales Office
or Office of Quality Manager
DENISON HYDRAULICS GmbH
Gerresheimer Strasse 9
D-40721 Hilden
Deutschland

See Installation & Operation Guidelines under Procedures.

**IMPROVEMENTS AND CHANGES
WORTH NOTING**

1. Improved power supply specification — 22-29VDC(min-max): unit will tolerate overvoltage excursions up to 40 volts.

The old version specified 24-28VDC, (minimum to maximum). If the input voltage accidentally exceeded 30 volts, including any AC peaks, the converter would fail permanently. Mobile applications with battery chargers could exceed the 30 volts; but also fixed industrial applications with unregulated, 28VDC power supplies will readily exceed 35 volts due to AC input tolerance and output load variations.

2. Eliminated the two 1/2 amp Micro-Fuses. The new DC-DC converter has internal short-circuit protection, eliminating the need for fuses. Total current available from $\pm 15\text{Vdc}$ source is 330mA, that is, onboard and off-board. Unit has over-current protection.
3. Front panel STEP COMMAND is functional in both LOCAL and REMOTE modes. Older versions only worked in LOCAL mode.(This applies to Eurocard version S20-14078 only).
4. Added option to permit isolated power source for E-STOP function. This option is factory set to operate as previous versions. If isolated power source is desired, move jumper JP4 from position A-B (internal GND) to B-C (isolated GND) and connect the isolated power ground to terminal C24 E-STOP RET. It made sense to provide this isolation option to the E-STOP function since the SOFT-STOP and REV CMD function can be isolated.

NOTE: Terminal C24 on versions prior to REV. C was REV CMD RET. Terminal C22 is now the REV CMD RET and SOFT-STOP RET. (We ran out of terminals).

5. Added 400 Hz, as a third choice for pulse-width modulation frequency. The factory set is 200Hz, JP2 (A-B). For 400Hz set jumper JP2 to B-C and for 120Hz remove the jumper (store the jumper on one of the pins).
6. The Ramp time minimum values have increased to 0.2 and 0.8 seconds. This should be of little consequence in most application. The ramp function can be shut off if desired.
7. The IA and IB LED's illuminate somewhat proportionately to the output current. This is a good troubleshooting tool.

	PAGE
European EMC Directive 89/336/EEC Declaration of Conformity	i
product up-date information	ii
table of contents	iii
technical specifications	1-2
power supply requirements	1
reference voltages	1
remote inputs	1
operating temperature	1
ramp generator	1
output driver	1
feedback inputs	1
input command disable	1
emergency stop input	1
reverse CMD input	1
soft stop input	1
LED indicators	2
potentiometer adjustments	2
test points	2
mechanical	2
I/O connector pin assignment	2
product description	3
system features	3
general	3
functional description	4-5
output	4
PWM frequency	4
input	4
ramp generator	4
controls & indicators	4
emergency stop option	4
soft stop option	5
reverse CMD option	5
ramp-at-zero option	5
closed-loop-control	5
procedures	6
installation & operation guidelines	6
set-up procedure	6
installation drawings	7-9
power supply outline	7
900 drivercard outline	8
jumper & switch settings	9
900 driver functional block diagram	10
input signal options diagrams	11-12
remote voltage & potentiometer	11
current-loop with interlock	12
application diagrams	13-19
open-loop control scheme	13
closed-loop control scheme	13
most common application	14
open-loop speed w/ hp limit	15
closed-loop speed w/ command forward	16
closed-loop speed w/ com. forward & hp lmt	17
closed-loop speed w/ pi	18
closed-loop speed w/ pi & hp lmt	19

TECHNICAL SPECIFICATIONS

POWER SUPPLY REQUIREMENTS	22-29VDC @ 1 Amp (nominal)	
REFERENCE VOLTAGES	<i>Available to user</i>	+15VDC @ 250 mA (max.) -15VDC @ 250 mA (max.) +10VDC @ 0.0025 Amps max. -10VDC @ 0.0025 Amps max.
REMOTE INPUTS	<i>Potentiometer</i>	10K Ohms nominal, 5K Ohms minimum
	<i>Input voltage range</i>	±5VDC, ±10VDC
	<i>Input impedance</i>	100K Ohms, 200K Ohms
	<i>Current loop input</i>	4-20mA, ±20mA
	<i>Current loop input impedance</i>	249 Ohms
	<i>Auxiliary voltage input</i>	±10VDC
	<i>Reverse command input</i>	+15 - +24VDC
	<i>Soft stop input</i>	+15 - +24VDC
OPERATING TEMPERATURE RANGE	0-65°C	
RAMP GENERATOR	<i>Switchable (DIP switch)</i>	On or Off
	<i>Positive ramp (rising) range A</i>	0.2-6 sec.
	<i>Positive ramp (rising) range B</i>	0.8-40 sec.
	<i>Negative ramp (falling) range A</i>	0.2-6 sec.
	<i>Negative ramp (falling) range B</i>	0.8-40 sec.
OUTPUT DRIVER	<i>Pulse width modulation (PWM) driver with current feedback and short circuit protection.</i>	
	<i>PWM frequency</i>	120Hz, no jumper 200Hz, JP2 position A-B 400Hz JP2 position B-C
	<i>I_(A,B) minimum</i>	0-460mA
	<i>I_(A,B) maximum w/24 Ohm load</i>	I _{min} - 800mA
FEEDBACK INPUTS	<i>Horsepower limiting command</i>	±10VDC
	<i>Major loop</i>	±10VDC
INPUT COMMAND DISABLE	<i>Gnd to disable</i>	
EMERGENCY STOP INPUT	Apply +15 to 24VDC for normal operation Remove 24VDC for emergency stop. Remove jumper JP4 for isolated signal source.	
REVERSE CMD INPUT	No connection for normal operation. Apply +15V to 24VDC and GND to reverse command.	
SOFT STOP INPUT	JP3 factory set to position B-C, soft stop disabled. Set JP3 to position A-B to enable soft stop. Apply 24VDC and GND for normal operation. Remove 24VDC for soft stop.	

TECHNICAL SPECIFICATIONS

LED INDICATORS

<i>Power</i>	±15VDC supply operational
<i>I_A</i>	Output current to coil A
<i>I_B</i>	Output current to coil B
<i>Stop</i>	Both "A" & "B" coils disabled, same as emergency stop.

POTENTIOMETER ADJUSTMENTS

<i>+ Ramp</i>	Adjusts positive ramping time
<i>- Ramp</i>	Adjusts negative ramping time
<i>I_A Min</i>	Adjusts coil A minimum current
<i>I_B Min</i>	Adjusts coil B minimum current
<i>I_A Max</i>	Adjusts coil A maximum current
<i>I_B Max</i>	Adjusts coil B maximum current

TEST POINTS

<i>In</i>	Input command (±10VDC)
<i>Ramp</i>	Ramp output (±10VDC)
<i>Out</i>	Coil output current scaled to ±1mV per ±1mA Coil A is a positive value, Coil B is a negative value
<i>Gnd</i>	Signal ground reference

MECHANICAL

<i>Dimensions, panel mounted</i>	100 x 176 mm (3.94 x 6.90 in.)
<i>Connector</i>	32 screw-terminals, 2 piece construction for quick disconnect
<i>Weight</i>	0.22 kg (0.484 Lbs.)

I/O CONNECTOR PIN ASSIGNMENTS S20-14087

A2: +10V Ref. @ 2.5mA	C2: Test Point Command In
A4: -10V Ref. @ 2.5mA	C4: Test Point Ramp First-Stage Ampl.
A6: ±5V Command	C6: Test Point Ramp Out
A8: ±10V Command	C8: Test Point Current Out Coil A/B
A10: ±10V AUX Command	C10: Coil A PWM Output
A12: Signal Ground	C12: Coil A Return
A14: Current-Loop In	C14: Ramp-at-Zero Open-Collector Unit
A16: Current-Loop Ret	C16: Command Inverted
A18: Major-Loop Feedback	C18: Coil B PWM Output
A20: HP Limiting Command	C20: Coil B Return
A22: Soft-Stop Input	C22: Soft-Stop Return / Rev. Comm. Ret.
A24: Reverse Command Input	C24: E-Stop Return
A26: Signal Ground	C26: Command Disable CMDDIS/
A28: E-Stop Input	C28: +15V @ 250mA Power Out
A30: DC Power Input	C30: -15V @ 100mA Power Out
A32: Power Ground	C32: Power Ground

SYSTEM FEATURES

- Controls 9A electro hydraulic control for Gold Cup Series and premier series open loop pumps
- Open or closed loop control (w/options card S20-11716-0)
- Panel mounting (see S20-14078-0 for eurocard version)
- Separately adjustable positive and negative ramps (0.2-40 sec.)
- Multiple input commands
- Remote potentiometer (10K CT)
- $\pm 5\text{VDC}$ and $\pm 10\text{VDC}$ voltage inputs
- $+4\text{-}20\text{mA}$ and $\pm 0\text{-}20\text{mA}$ current loop inputs
- Auxiliary inputs
- Soft stop option
- Emergency stop option
- Reverse command option
- Special field calibration features
- Special safety features

GENERAL

Jupiter driver card S20-14087-0 is a bidirectional pulse-width modulated current coil driver used for proportional open-loop control of the 9A electro hydraulic controlled pumps. Input commands to the card may be voltages, current loop, or potentiometer, single ended or differential. Multiple input commands are permitted but must be interlocked by the user to insure that the card is controlled by only one input at a time. The card also features two ranges of positive and negative ramping, remote emergency shutdown control, options for soft stop, emergency stop and reverse command, as well as provisions for closed-loop control with the Jupiter options card S20-11716. The driver card is packaged for panel mounting and may be operated with any 22-29VDC filtered, 1 amp power supplies or with the Jupiter 900 power supply 762-30026, which provides the required DC power in a panel mount package.

Open loop control

The driver card with its power supply accessory is used for open-loop control. It provides multiple input commands and ramping. The panel mounted power supply furnishes the driver card with regulated DC power and features screw terminals for simplified panel wiring.

Closed loop control

The options card, S20-11716, is used in conjunction with the driver card for precise closed-loop control. It features digital and DC tachometer feedback, horsepower limiting, and PI control of feedback error. A panel mounted eurocard holder with screw terminals is available for easy mounting. Power for the options card is obtained from the driver card's power supply.

OUTPUT

The output stage of the driver card is a two channel PWM (Pulse Width Modulated) current source with current feedback for precise control of the current through the coil regardless of the changes in coil resistance. The two outputs are protected against short circuits across the coil and short circuits to ground.

PWM frequency

The frequency of the **PWM** high current driver is factory set to 200Hz (JP2 A-B). **JP2** allows the frequency to be lowered to 120Hz by removing the **JP2** jumper, or raised to 400Hz by moving **JP2** to position B-C.

INPUT

This panel-mounted version of the 900 driver operates with remote signals only; it does not have a local command potentiometer.

The user has a choice of voltage, current-loop or potentiometer input signals. Voltage inputs may be $\pm 5V$, or $\pm 10V$. Current-loop inputs are differential 4-20mA1 or $\pm 0-20mA$. DIP switches on board are for current-loop set-up.

An **auxiliary** $\pm 10V$ input is also available. This input provides the user more input options. With all the input options provided, it is the user's responsibility to interlock multiple inputs if driver card is to be controlled by one input at a time.

¹ The **reverse CMD** input can be used to obtain bidirectional operation.

RAMP GENERATOR

Adjustable positive and negative ramping of the output is provided in two ranges of 0.2-6 and .0.8-40 seconds. Ramping, on-off, and ramping ranges are selected by dip switches on the card.

CONTROLS AND INDICATORS

Key indicators, potentiometer adjustments, switches and test points are located on the circuit board for monitoring, set-up and calibration purposes. **LEDs** are provided for indicating the status of the power (internal $\pm 15VDC$ supplies), the coil that is energized and the state of the emergency stop function.

Potentiometer adjustments include **\pm ramps**, **I_{A,B} min** and **I_{A,B} max**. Test points are furnished for measurement of the input, output, ramp and signal ground.

EMERGENCY STOP OPTION

The emergency stop (E-stop) input controls the K1 relay that provides 24VDC to the output driver stage. Applying logic level +15 to 24VDC to the E-stop enables the driver card output stage. Removing the E-stop signal will abruptly halt the output current. (See **soft-stop** option). In revision level C and up an isolated E-stop signal option is provided. If an isolated E-stop signal is required, remove the JP4 jumper and connect the isolated signal common to terminal C24.

SOFT STOP OPTION

The **soft stop** option is used to set the output current to zero at a rate set by the **ramp** circuit. Placing **JP3** in the A-B position will enable the **soft stop** option, position B-C will disable the **soft stop** option. If the **soft stop** is enabled 24VDC and **GND** must be connected to the **soft stop** input for normal operation. Removing 24VDC from the **soft stop** input will turn off the output at a rate set by the **ramp** settings.

REVERSE CMD OPTION

Connecting 24VDC and **GND** across the **reverse CMD** input will cause the output to switch the current from one channel to the other at a rate set by the **ramp** circuit. This will allow a unipolar command signal to control the pump on both sides of center.

WARNING: Once the **reverse CMD** input has been energized loss of this signal will reverse the driver cards output signal.

RAMP-AT-ZERO OPTION

The **ramp-at-zero** is an output that indicates when the ramp circuit output is at zero. The **ramp-at-zero** output is 15VDC when ramp is at zero and **0VDC** when ramp is not at zero. One application for the **ramp-at-zero** function is to hold the integrator of the Jupiter options card, S20-11716, at zero when system command is zero.

CLOSED-LOOP-CONTROL

The driver card operating as a stand alone driver is used primarily for open-loop control. With the **Jupiter options card**, S20-11716, the driver card can be used for closed-loop speed control systems. The options card provides digital encoder and DC tachometer feedback, horsepower limiting and PI control of the feedback error.

INSTALLATION & OPERATION GUIDELINES

- For EMC compatibility, card must be installed in a NEMA 4 or equivalent enclosure; connect enclosure to earth ground.
- Shield (screen) all wires entering enclosure. Connect card end of shield to earth ground. Leave other end of shield open.
- Use Denison Hydraulics recommended power supply P/N 762-30036.
- Disconnect power before inserting or removing card.
- Use high resistance meter for all testpoint measurements, $R_i > 100K$.
- Maximum wire length between driver card and pump 9A control valve is 150 feet of 16 AWG, operating at minimum 22VDC supply voltage, 0.35A coil current and 80°C fluid temperature. When using 14 AWG distance can be increased to 240 feet.

SET-UP PROCEDURE

1. With the hydraulic system de-energized, connect the Jupiter 900 driver card according to the attached block diagram, then apply 24VDC to the driver card. The **power LED** should be illuminated and the **stop LED** should not be illuminated.
2. If the **power LED** is not lit, check the wiring and apply power again.
3. Connect a **DVM** (digital volt meter) to the IOUT test point and the **GND** test point on the front panel. Turn **IA max** and **IB max** CCW. Apply a positive 3% command signal to the appropriate input. Adjust the **IA min** potentiometer until a value of +0.124VDC (+0.124A) is read on the **DVM**. Apply a negative 3% command signal to the appropriate input. Adjust the **IB min** potentiometer until a value of -0.124VDC (-0.124A) is read on the **DVM**. This is a preliminary setting.
4. Apply a positive 100% command signal to the appropriate input, then adjust the **IA max** potentiometer to give a value of +0.30VDC (+0.30A) on the **DVM**. Apply a negative 100% command signal to the appropriate input, then adjust the **IB max** potentiometer to give a value of -0.30VDC (-0.30A) on the **DVM**. This is a preliminary setting.

Note: Before energizing hydraulic system make sure that system can handle high flow rate and that max pressure limit is set to prevent system damage.

5. Set the command signal to 0% and energize the hydraulic system. Slowly set command signal to +100% and then adjust **IA MAX** potentiometer for desired max hydraulic flow. Slowly decrease command signal while observing DVM at IOUT testpoint. Set command slightly above the I_{MIN} trip point and then adjust **IA MIN** potentiometer until the minimum hydraulic output is at the desired level. Repeat the **IMAX** and **IMIN** adjustments for best hydraulic operating characteristic. Adjustments have slight interaction.
6. For bi-directional systems repeat step 5 above with a negative command signal and adjust **IB MAX** and **IB MIN** for best operating characteristics.

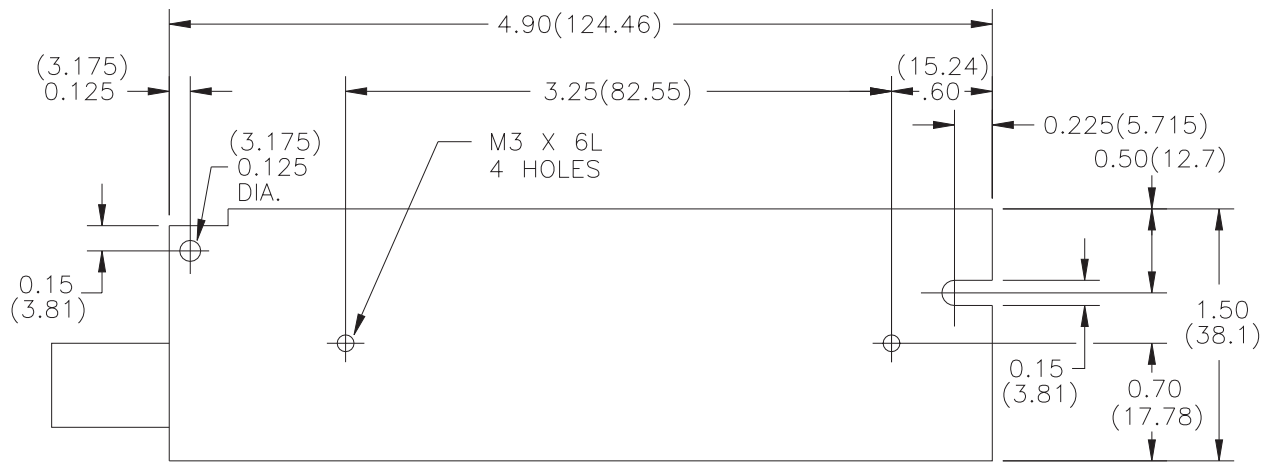

[mm]

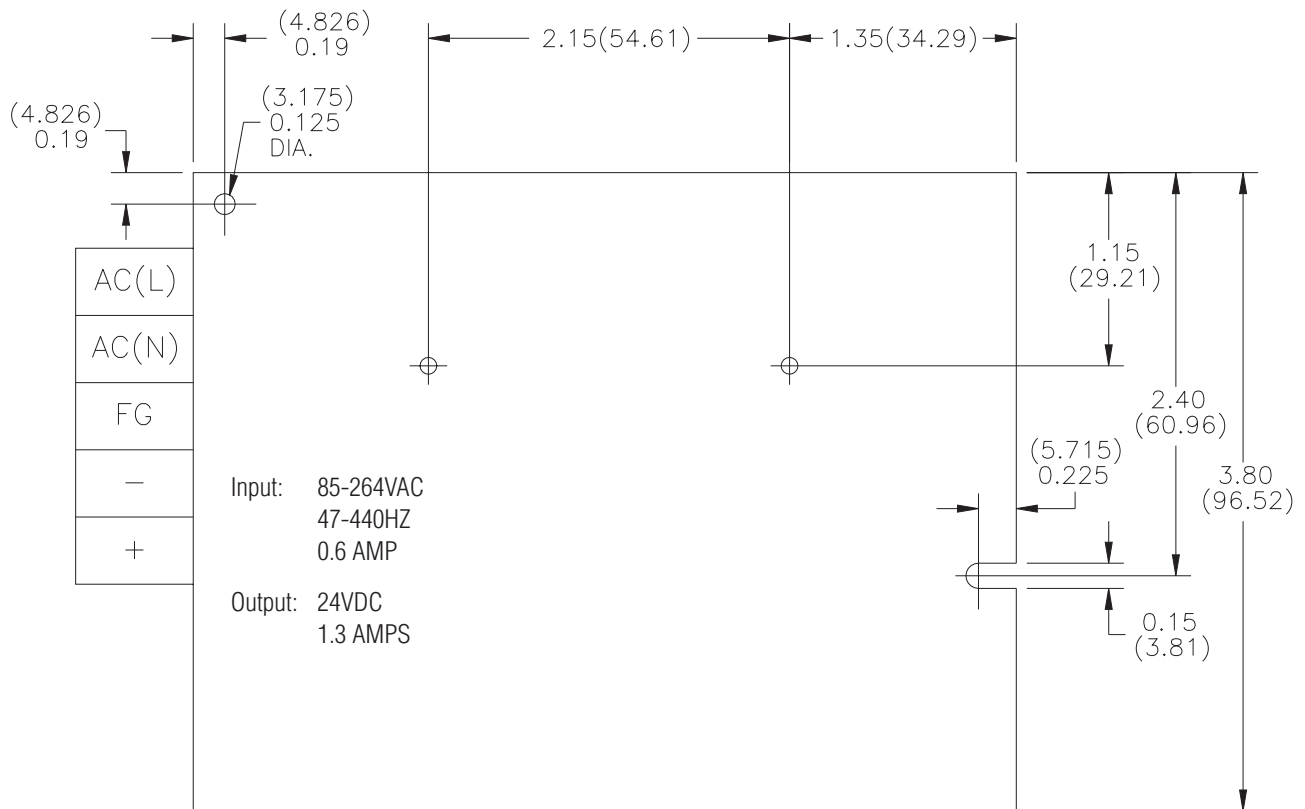

BOTTOM VIEW

762-30026 POWER SUPPLY MOUNTING HOLES
DIMENSIONS IN INCHES [MILLIMETERS]

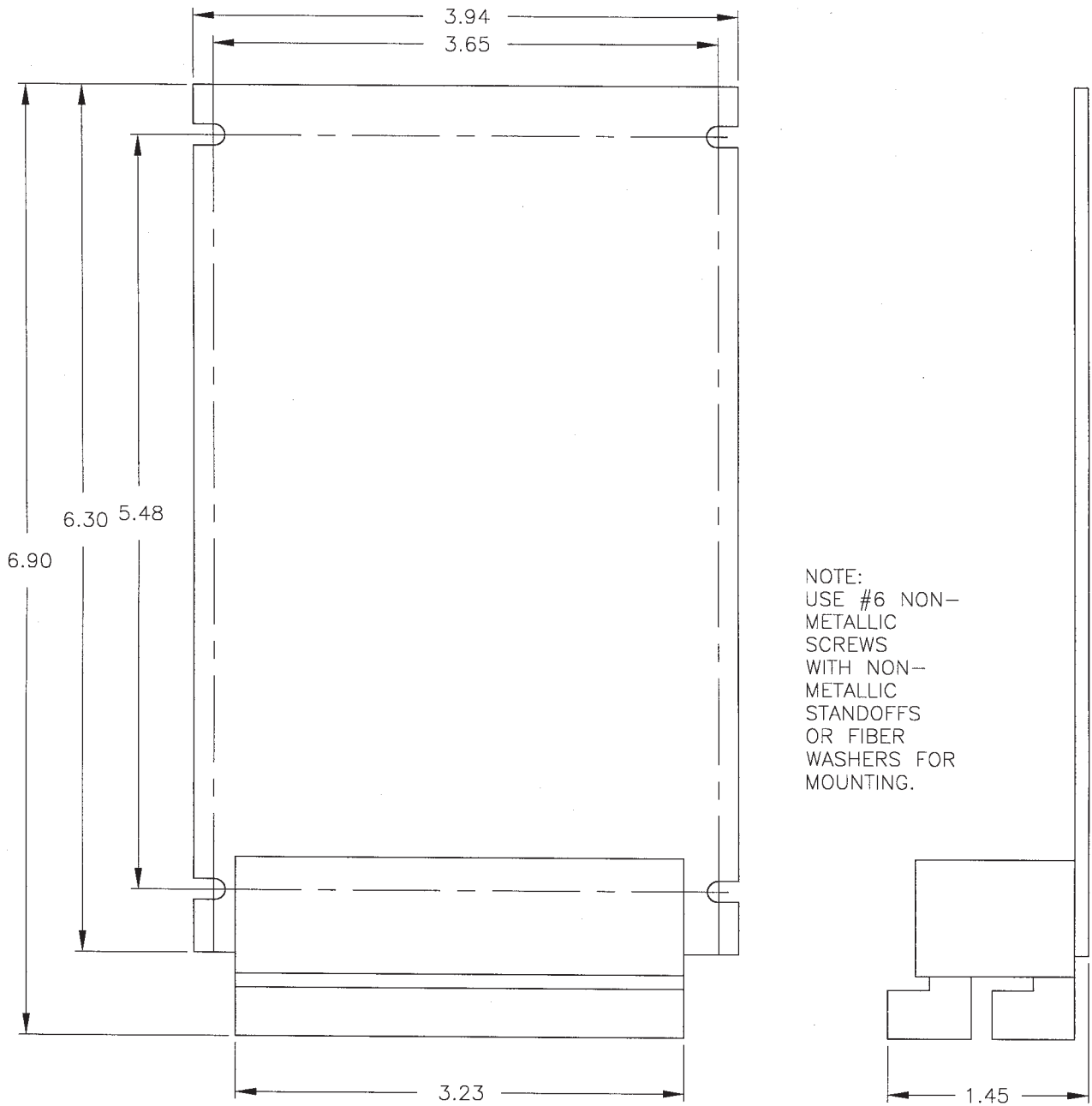

S20-14087 900 DRIVER PANEL MOUNT
MOUNTING DIMENSIONS

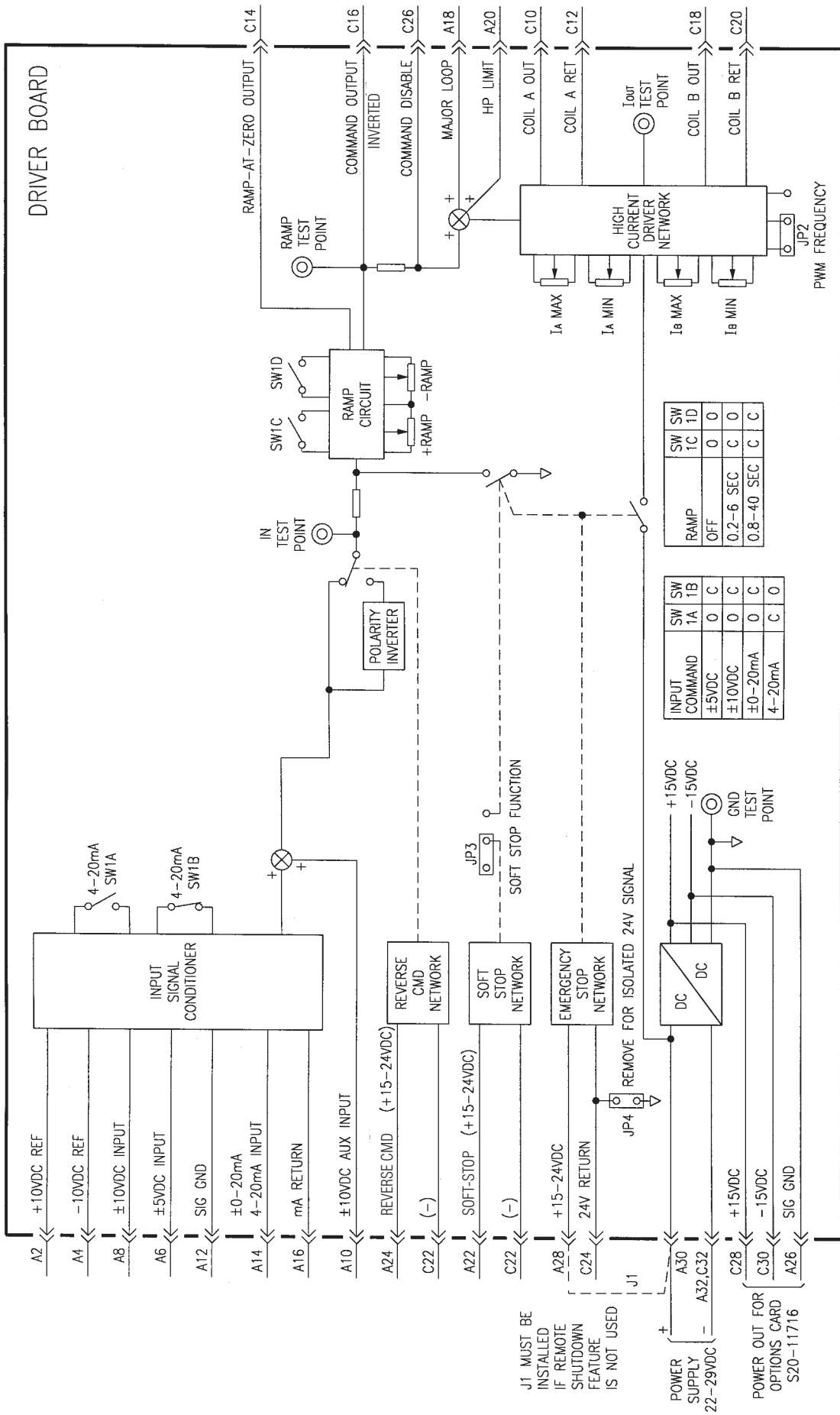

J1 MUST BE INSTALLED IF REMOTE SHUTDOWN FEATURE IS NOT USED

POWER SUPPLY 22-29VDC
 +
 - A30, C32
 +15VDC
 -15VDC
 SIG GND
 POWER OUT FOR OPTIONS CARD S20-11716

INPUT COMMAND	SW 1A	SW 1B	SW 1C	SW 1D
±5VDC	0	C	0	0
±10VDC	0	C	C	0
4-20mA	0	C	C	C

RAMP	SW 1C	SW 1D
OFF	0	0
0.2-6 SEC	C	0
0.8-40 SEC	C	C

DIP SW1 MARKINGS
 0 = OPEN SW1A = 1
 C = CLOSED (ON) B = 2
 C = 3
 D = 4

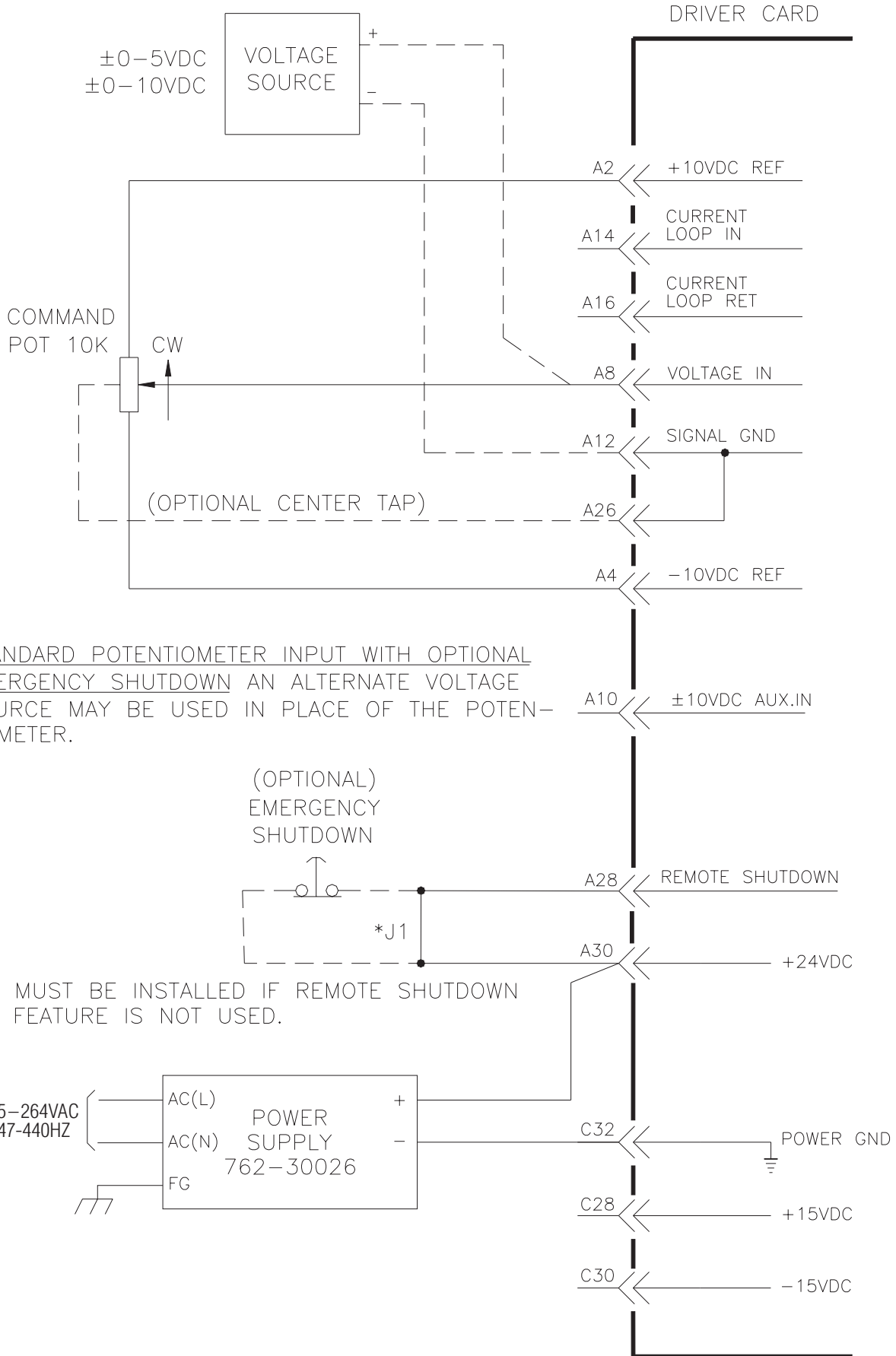

STANDARD POTENTIOMETER INPUT WITH OPTIONAL EMERGENCY SHUTDOWN AN ALTERNATE VOLTAGE SOURCE MAY BE USED IN PLACE OF THE POTENTIOMETER.

*J1 MUST BE INSTALLED IF REMOTE SHUTDOWN FEATURE IS NOT USED.

REMOTE VOLTAGE AND POTENTIOMETER INPUT CONNECTIONS

STANDARD CURRENT LOOP INPUT INTERLOCKED WITH AN AUXILIARY POTENTIOMETER INPUT AND OPTIONAL EMERGENCY SHUTDOWN.

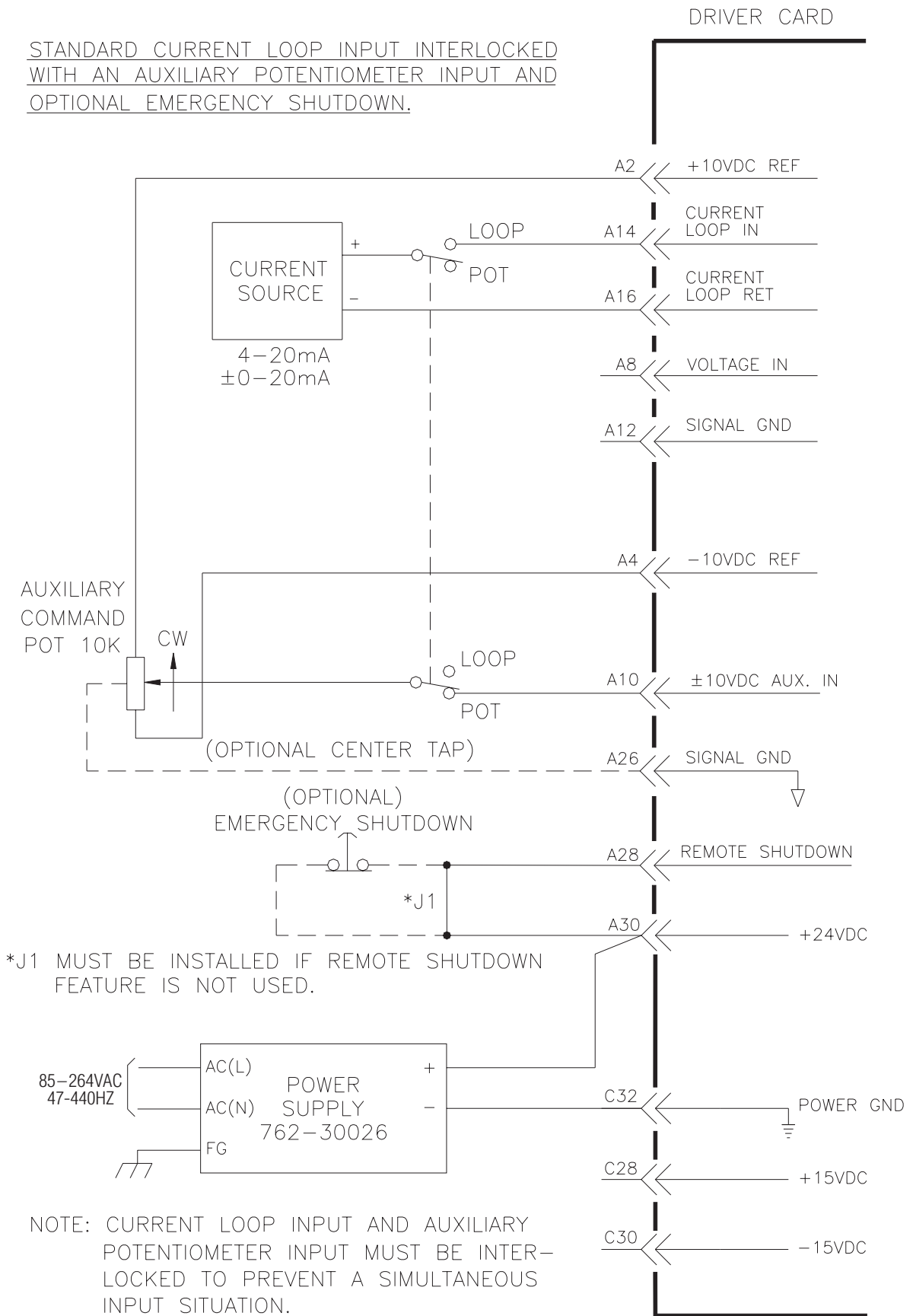

NOTE: CURRENT LOOP INPUT AND AUXILIARY POTENTIOMETER INPUT MUST BE INTERLOCKED TO PREVENT A SIMULTANEOUS INPUT SITUATION.

CURRENT LOOP INPUT CONNECTIONS

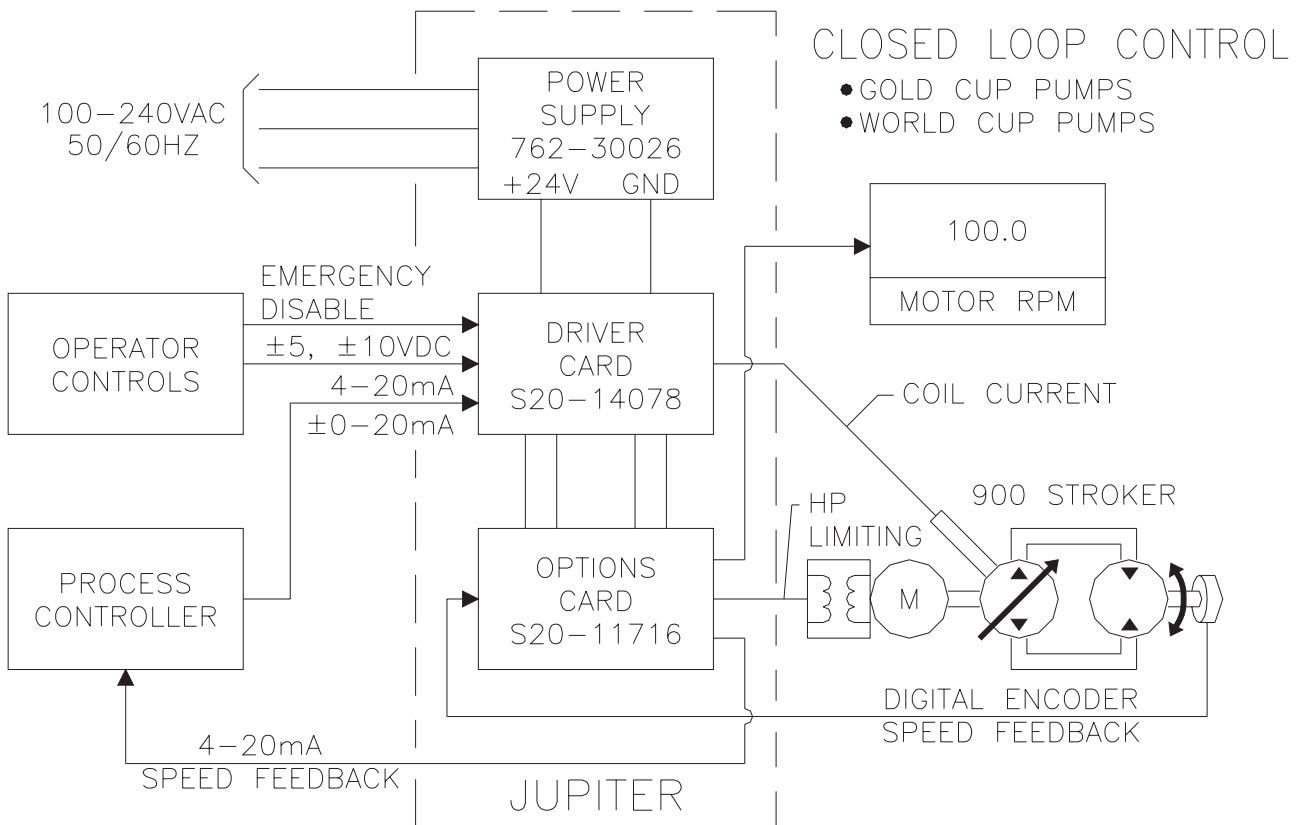
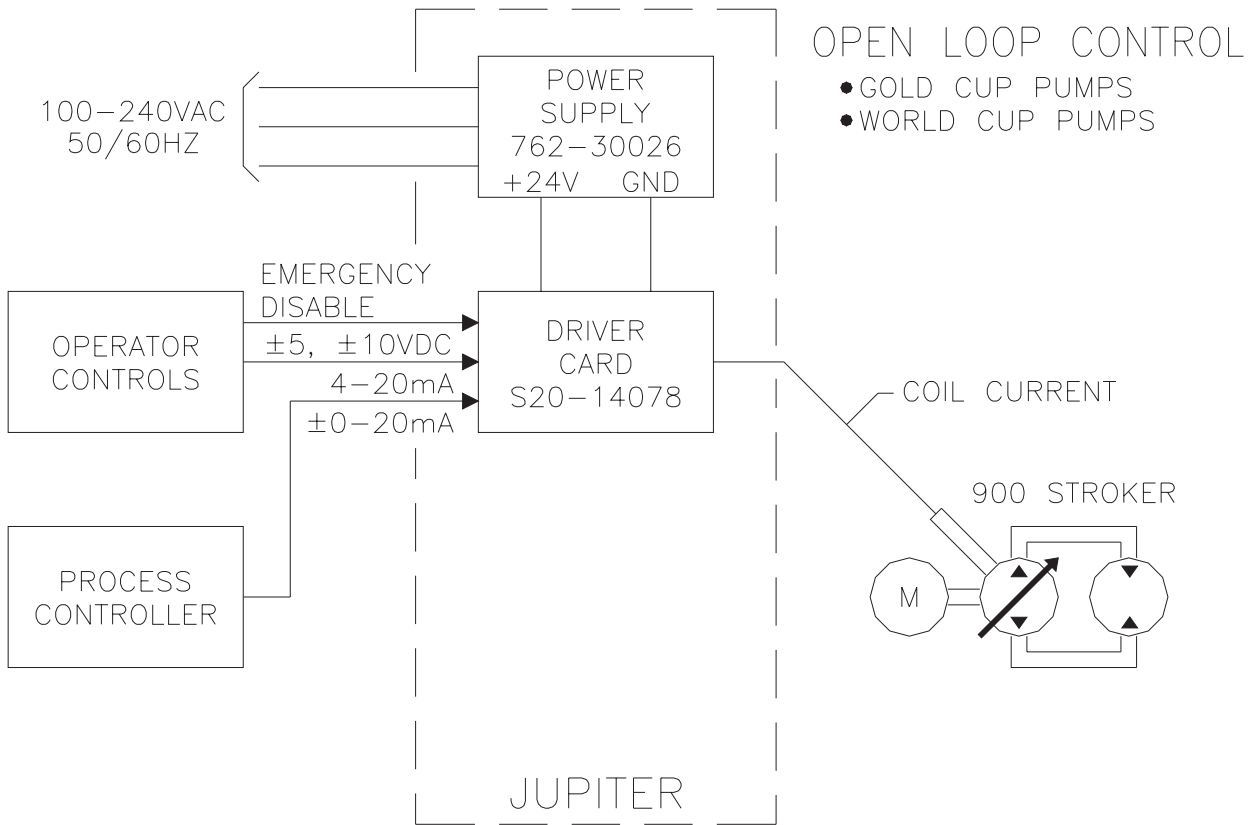

DIP SW1 MARKINGS

- SW1A=1
 0 = OPEN
 B = 2
 C = CLOSED (ON)
 C = 3
 D = 4

INPUT COMMAND	SW 1A	SW 1B	SW 1C	SW 1D
±5VDC	0	C		
±10VDC	0	C		
±0-20mA	0	C		
4-20mA	C	0		

RAMP	SW 1C	SW 1D
OFF	0	0
0.2-6 SEC	C	0
0.8-40 SEC	C	C

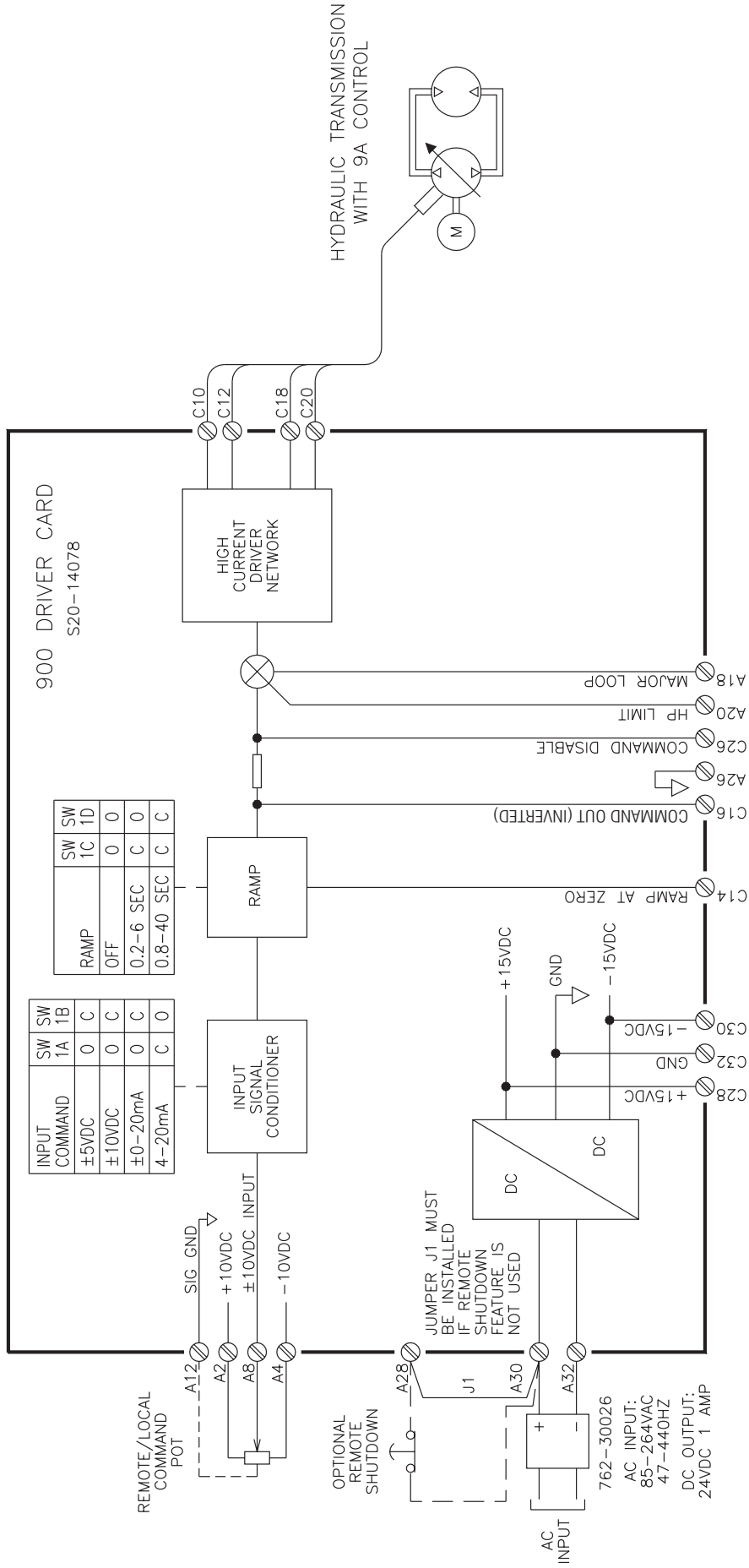

Block Diagram
 Jupiter 900 Driver
 Minimum Circuit for
 Most Common Applications

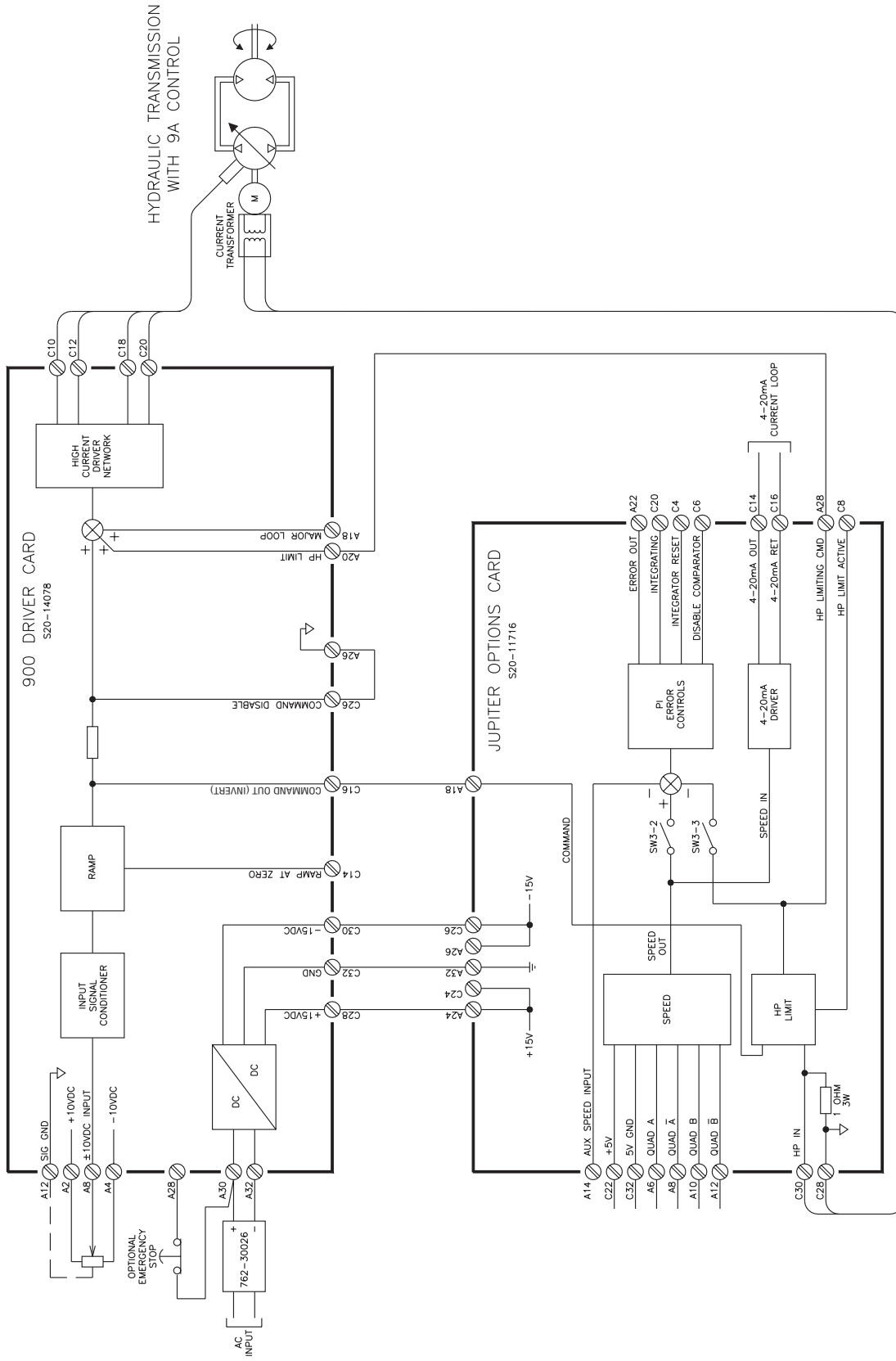

BLOCK DIAGRAM
 JUPITER 900 DRIVER WITH OPTIONS CARD
 OPEN-LOOP SPEED CONTROL WITH HORSEPOWER LIMITING

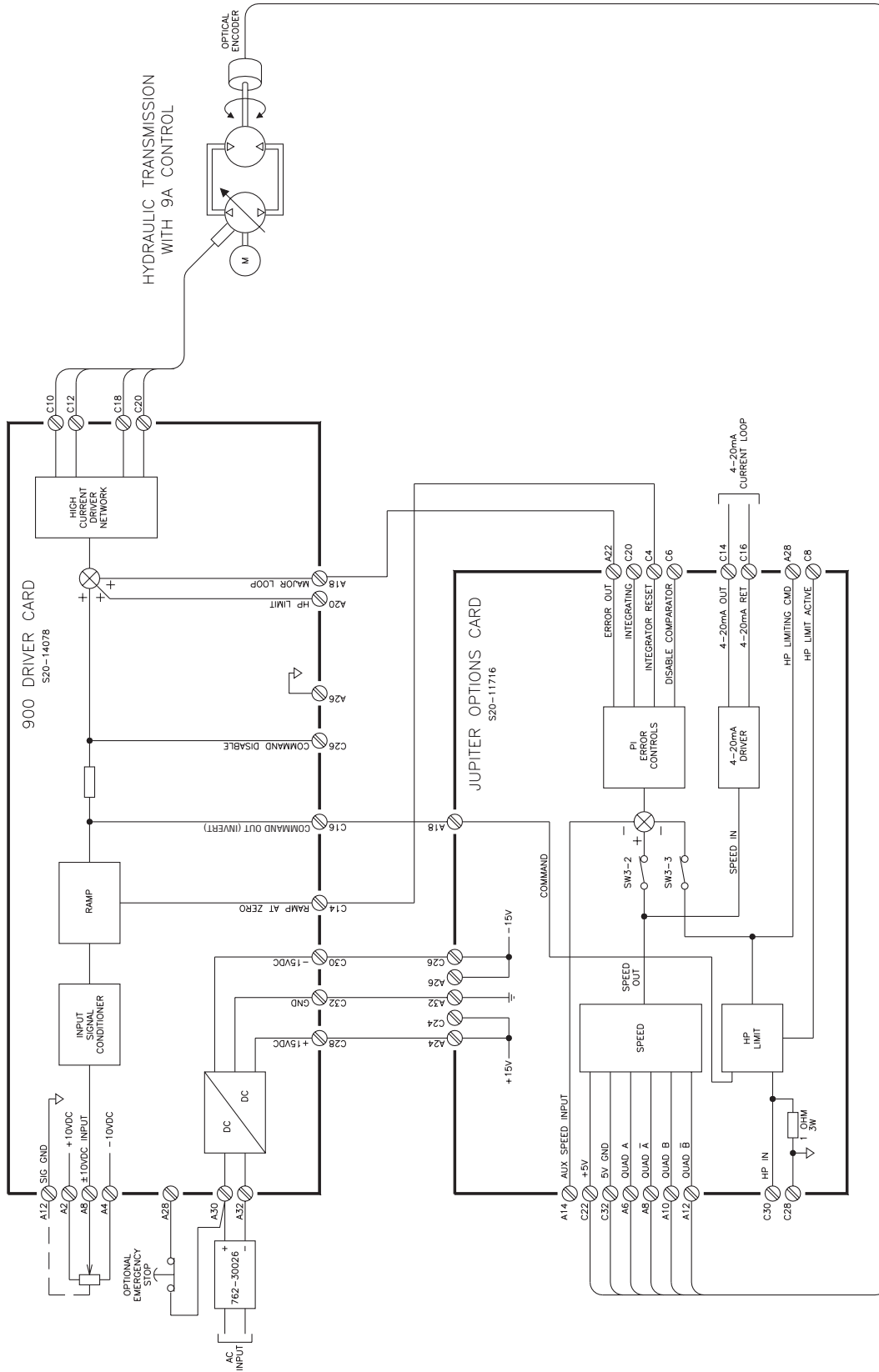

BLOCK DIAGRAM

JUPITER 900 DRIVER WITH OPTIONS CARD
CLOSED-LOOP SPEED CONTROL WITH COMMAND FEEDFORWARDING

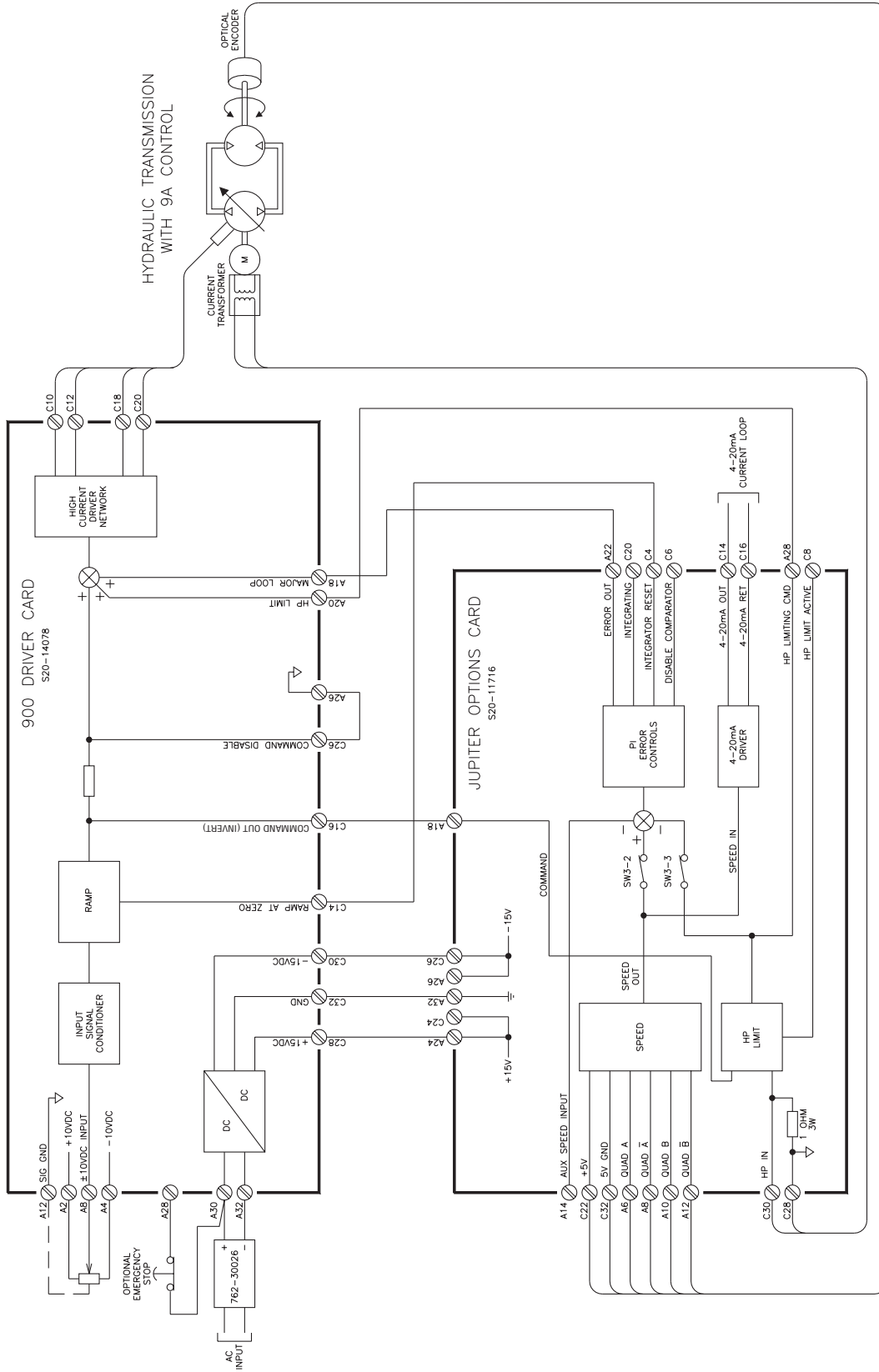

BLOCK DIAGRAM
 JUPITER 900 DRIVER WITH OPTIONS CARD
 CLOSED-LOOP SPEED CONTROL WITH
 COMMAND FEEDFORWARD AND HORSEPOWER LIMITING

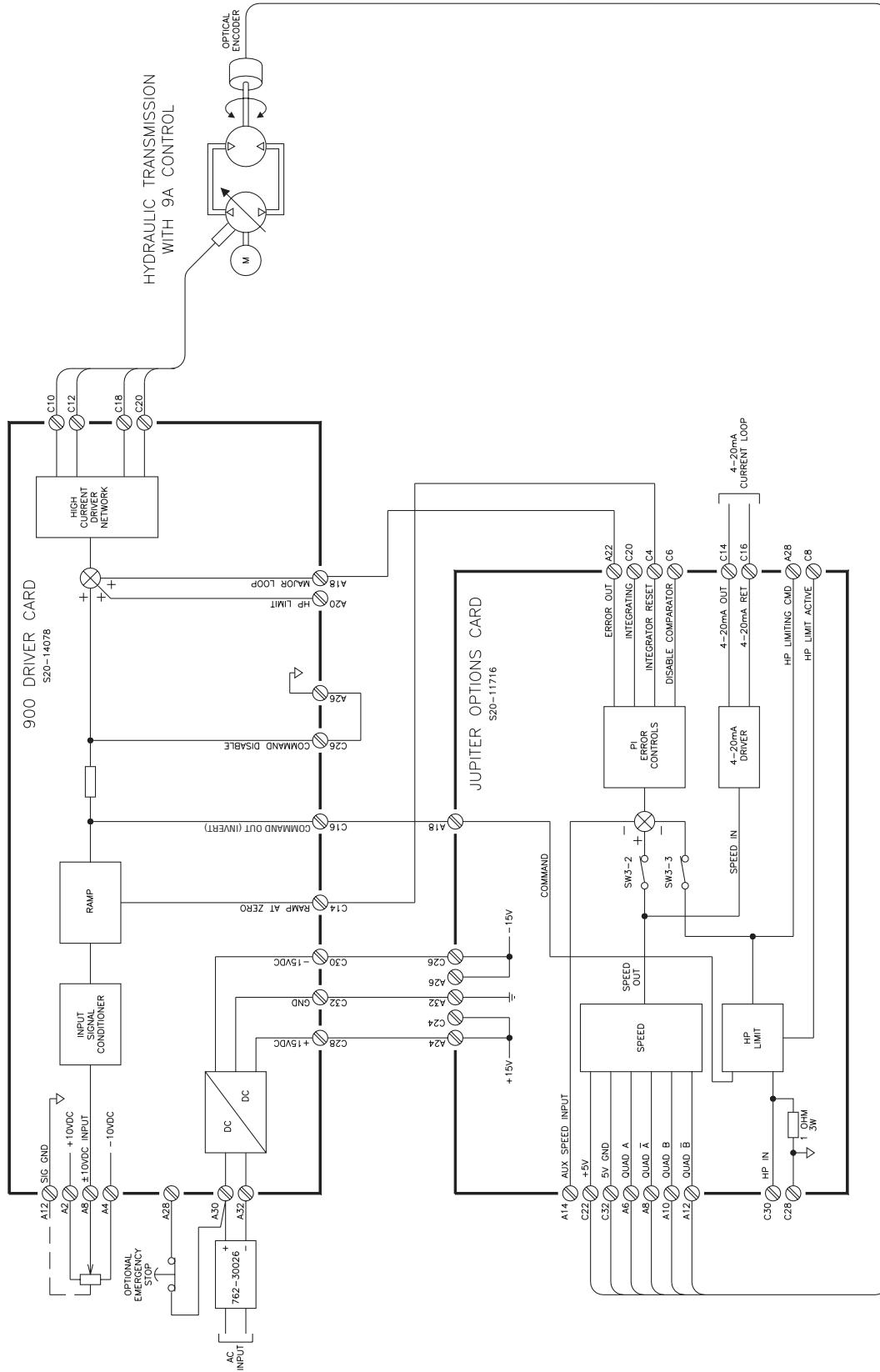

BLOCK DIAGRAM
 JUPITER 900 DRIVER WITH OPTIONS CARD
 CLOSED-LOOP SPEED CONTROL WITH PI

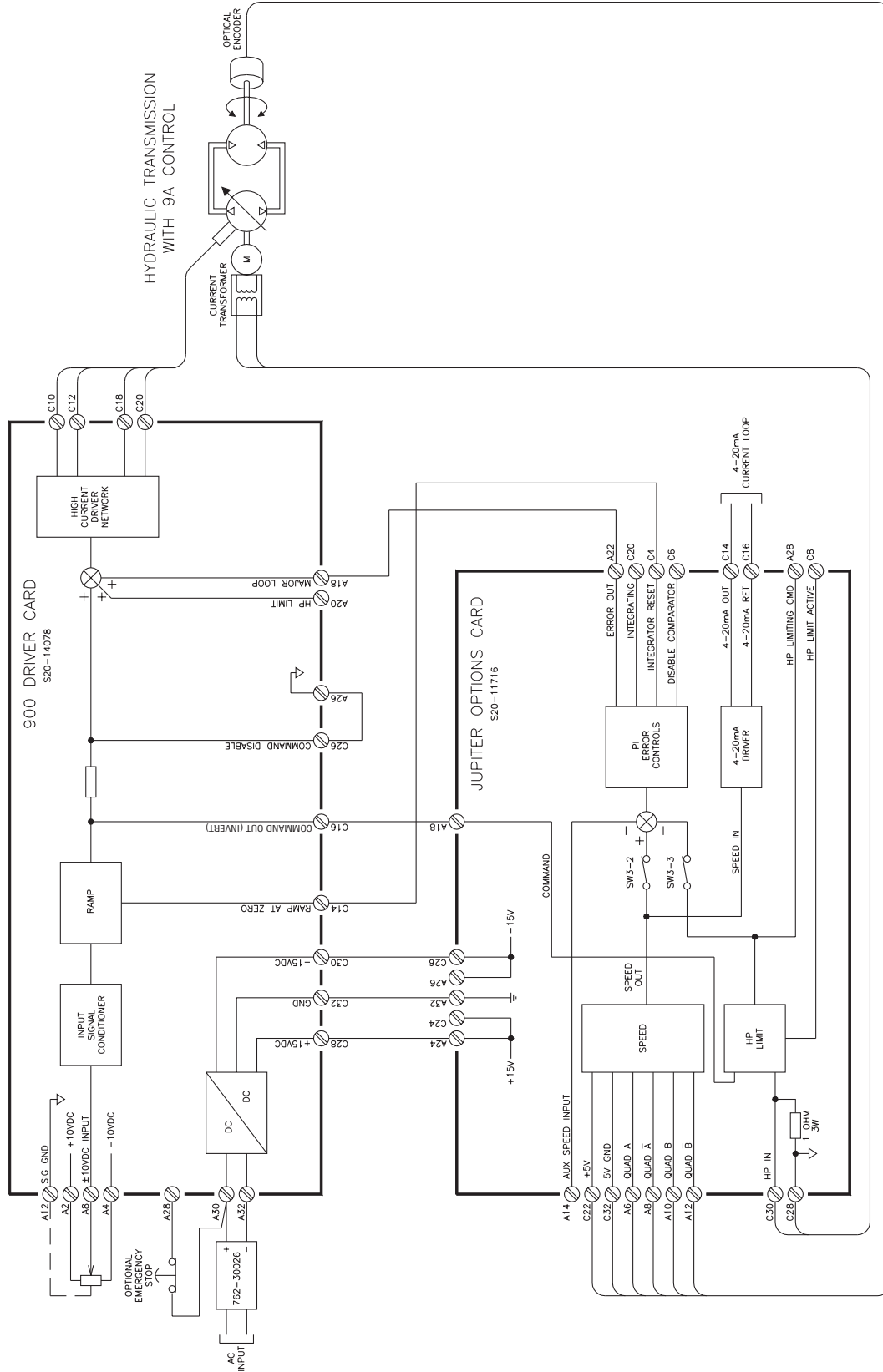

BLOCK DIAGRAM
 JUPITER 900 DRIVER WITH OPTIONS CARD
 CLOSED-LOOP SPEED CONTROL WITH
 PI AND HORSEPOWER LIMITING

International Distributors

In Europe:

Cyprus
Eastern Europe
The Faroe Islands
Finland
Greece
Iceland
Norway
Portugal
Switzerland
Turkey

In Africa:

Algeria
Egypt
Ivory Coast
Morocco
Nigeria
South Africa
Togo
Tunisia

In Middle East:

Iran
Israel
Lebanon
Pakistan
Qatar
Saudi Arabia
Syria
United Arab Emirates

In Far East:

Indonesia
Korea
Malaysia
New Zealand
Philippines
Thailand

Australia

DENISON HYDRAULICS Pty. Ltd.
41-43 St. Hillers Road
P.O. Box 192
Auburn, N.S.W. 2144
Tel. (612) 9646 5200
Fax (612) 9643 1305
Other sales offices:
Queensland
South Wantirna Victoria
Western Australia

Austria

DENISON HYDRAULIK GmbH
Zweigniederlassung Linz
Haidbachstraße 69
A-4061 Pasching
Tel. (43) 7229 4887
Fax (43) 7229 63092

Benelux

DENISON HYDRAULICS
BENELUX B. V.
Pascalstraat 100
3316 Dordrecht
Holland
Tel. (31) 786179 900
Fax (31) 786175 755

Canada

DENISON HYDRAULICS
CANADA Inc.
2320 Bristol Circle, Unit 1
Oakville, ON L6H 5S2
Tel. (905) 829 5800
Fax (905) 829 5805
Other sales offices:
Montreal, QC
Calgary, AB

China, P.R.

DENISON HYDRAULICS Ltd.
3F, No. 1, Mao Jia Zhai, Bai Lian Jing
Pudong New Area
Shanghai 200126,
Tel. (86) 21 5886 8991
Fax (86) 21 5886 1978

Denmark

DENISON HYDRAULIK
DENMARK A/S
Industrikrogen 2
DK-2635 Ishøj
Tel. (45) 4371 15 00
Fax (45) 4371 15 16

Finland

DENISON HYDRAULICS
P.O. Box 36
FIN-08101 Lohja
Tel. (358) 208 33 045
Fax (358) 207 33 045

France

DENISON HYDRAULICS
FRANCE SA
14, route du Bois Blanc
BP 539
18105 Vierzon
Tel. (33) 2 48 53 01 20
Fax (33) 2 48 75 02 91
Other sales offices:
Bordeaux
Lyon
Paris

Germany

DENISON HYDRAULIK GmbH
Herderstrasse 26
D-40721 Hilden
Tel. (49) 2103 940-6
Fax (49) 2103 940-880
Other sales offices:
Dresden
Hanover
Stuttgart

Great Britain

DENISON HYDRAULICS U.K.
Ltd.
Kenmore Road
Wakefield 41, Industrial Estate
Wakefield, WF20XE
West Yorkshire
England
Tel. (44) 19 24 826 021
Fax (44) 19 24 826 146
Other sales offices:
Burgess Hill

Hong Kong, N. T.

DENISON HYDRAULICS Ltd.
Unit 3, 25/F Wharf Cable Tower
9 Hoi Shing Road
Tsuen Wan
Tel. (852) 24988381
Fax (852) 24991522

Italy

DENISON HYDRAULICS S.r.l.
Viale Europa 68
20090 Cusago
Tel. (39) 2 90 33 01
Fax (39) 2 90 39 06 94

Japan

DENISON JAPAN Inc.
4-2-1 Tsujido-Shinmachi
Fujisawa 251,
Tel. (81) 466 35 3257
Fax (81) 466 35 2029
Other sales office:
Osaka

Mexico, Central America, South

America and Caribbean Countries Contact
DENISON HYDRAULICS Inc.
6167 NW 181 Terrace Circle North
Miami, FL 33015, USA
Tel. (305) 362 2246
Fax (305) 362 6220

Other European, Middle East

and African Countries Contact
DENISON HYDRAULICS
FRANCE SA
14, route du Bois Blanc
BP 539
18105 Vierzon Cedex
France
Tel. (33) 2 48 53 01 45
Fax (33) 2 48 53 01 46

Singapore

DENISON HYDRAULICS S.E.A.
Pte. Ltd.
No. 11 Lorong Tukang Dua
2261 Singapore
Tel. (65) 2687840
Fax (65) 2687847

Spain

DENISON HYDRAULICS, S.A.
Gomis, 1
08023 Barcelona
Tel. (34) 3418 46 87
Fax (34) 3211 65 07
Other sales offices:
San Sebastian

Sweden

DENISON HYDRAULICS
SVENSKA AB
Sporregatan 13
213 77 - Malmö
Tel. (46) 40 21 04 40
Fax (46) 40 21 47 26
Other sales offices:
Spånga

Taiwan, R.O.C.

DENISON HYDRAULICS Ltd.
6F-10, No. 79, Sec. 2, Roosevelt Road
Taipei,
Tel. (886) 2 3645101 / 3645102
Fax (886) 2 3639025

USA

DENISON HYDRAULICS Inc.
14249 Industrial Parkway
Marysville, OH 43040
Tel. 937 644 3915
Fax 937 642 3738
For nearest Distributor:
Call toll free 1 800 551 5956

Other sales offices:

Fulton, CA
Mulberry, FL
Moline, IL
Rock Island, IL
Kentwood, MI
Portland, OR
Collierville, TN
Arlington, TX
Houston, TX

Your local DENISON representative